

Variable-Structure-Variable-Gain Control of Robot Manipulators

機器臂之可變增益可變結構控制器設計

洪清寶 白能勝 郭英哲 喻國澗

Chin-Pao Hung, Neng-Sheng Pai, Yng-Chi Kuo, Kwo-Nan Yu

Department of Electrical Engineering
National Chin-Yi Institute of Technology
Taichung, Taiwan, R.O.C

Abstract

To achieve robust control of uncertain systems, conventional design of variable structure control systems (VSS) usually obtains high gain controllers, which may switch the control structures frequently and stimulates undesirable high frequency modes of the system easily. By introducing a variable-gain structure into the VSS as a transition between the conventional control structures, a variable-structure-variable-gain (VSVG) controller is developed for the motion control of robot manipulators. In the variable-gain structure, the control gains are tuned on-line to drive the system toward the target states before crossing the sliding surface and therefore the events of structure switching are reduced. The VSVG controller and its tuning method have been derived. Verification of the method by experiments of a robot control system is presented. The results show that the VSVG control can effectively alleviate the chattering phenomenon and achieve precise position control under severe load disturbance.

Keywords: variable structure control, chattering alleviation, robot.

摘要：

本文提出可變增益可變結構控制器之設計，以應用於系統參數變動劇烈之機器臂控制。不同於傳統可變結構控制器以固定的幾組控制器進行切換，本文所提出的控制器參數係藉由相位平面幾何即時的運算產生。當系統軌線離所設計滑動平面尚遠時，直接以固定增益參數迫使系統朝滑動平面移動，進入滑動區時，則以可變增益進行控制器參數之產生。經由理論及實驗的驗證，證明了本文所提出方法的有效性。

關鍵詞：可變結構控制，抖動消除，機器臂。

1. INTRODUCTION

With the consideration of modeling error, load disturbance, and measurement noise, robot control is undoubtedly a problem of uncertain system. To control such an uncertain system, the method of variable structure or sliding mode control was frequently employed [1][2-6]. A well-designed variable structure control system (VSS) has been proved to have advantages such as reduction of system order, decoupled design procedure, disturbance rejection, insensitivity to parameters variation, without the necessity of exact mathematical model, and simple in implementation [7]. Unfortunately difficulties such as chattering and high gain control usually prevent it from being applied to industrial plants directly. Switching in high frequency between different control structures mainly causes chattering, and high control gain is generally a result of over-conservation design for the worst case of uncertainty. To diminish the chattering, methods such as chattering alleviation control (CAC) [8][9], boundary layer method [1], sliding sector (hysteretic switching) [4], fuzzy sliding mode control (FSMC)[10][11], and productive networks control [12] were proposed and investigated by authors. Most of the mentioned methods used two or more fixed gain control structures and a filter-like scheme to deal with the chattering problem. Filtering can eliminate the high frequency component of the control signal so that frequent switching of the control structures may not happen. On the other hand, the boundary layer method adopts a continuous control law and a time varying sliding surface [1] to achieve chattering alleviation. But the result is more dependent of the thickness of the boundary layer, and difficulty occurs in practically implementing the time varying sliding surface [8]. The CAC suppresses the switching of control structures based on measurement of the chattering term [8][9], however the control law will rely upon precise modeling and measurement that is usually not available in uncertain systems. The variable-structure-variable-gain (VSVG) control proposed in this article is obtained by introducing a variable-gain structure into the conventional VSS. In the variable gain structure, the controller's gains are tuned on-line to drive the system toward the desired state before crossing the sliding surface, and as a result the events of structure switching are reduced. The proposed method has been formulated and proved for robot control. Experiments have been conducted for a PC-based robot control system, and the results were compared with those obtained by conventional VSS control and the boundary layer approach.

2. THE PROBLEM OF ROBOT CONTROL

Consider an n -link rigid robot manipulator described by the following dynamic equation [13]:

$$M(q)\ddot{q} + F(q, \dot{q}) + G(q) = u(t) \quad (1)$$

where $q(t)$ is the $n \times 1$ vector of joint angular positions, $u(t)$ is the $n \times 1$ vector of applied joint torques (control inputs), $M(q)$ is the $n \times n$ symmetric, positive inertia matrix, $F(q, \dot{q})$ is the $n \times 1$ vector of Coriolis and centrifugal forces and $G(q)$ is the $n \times 1$ vector of gravitational torques. With the physical constraints on the parameter terms of (1) in operating the robot, the following properties are usually assumed to facilitate the computation [14].

Property 1: The inverse of inertia matrix is uniformly bounded as

$$\|M(q)^{-1}\| \leq a \quad (2)$$

where a is a positive number.

Property 2: The norm of the vector of Coriolis and centrifugal force and gravitational torques is upper

bounded by a positive function of q as

$$\|F(q, \dot{q}) + G(q)\| < b_1 + b_2\|q\| + b_3\|\dot{q}\|^2 \quad (3)$$

where b_1, b_2 and b_3 are positive numbers.

With the mentioned properties and furthermore if all the signals in the robot system are bounded [15-16], then (1) can be decomposed into n subsystems as follows [17]:

$$m_{ii}(q)\ddot{q}_i + d_i(q, \dot{q}, \ddot{q}) = u_i \quad i = 1, \dots, n \quad (4)$$

where the subscript i refers to the i^{th} element, $m_{ii}(q)$ is the time-varying effective inertia seen at the i^{th} joint, and $d_i(q, \dot{q}, \ddot{q})$ is defined as

$$d_i(q, \dot{q}, \ddot{q}) \equiv \sum_{\substack{j=1 \\ j \neq i}}^n m_{ij}(q)\ddot{q}_j + f_i(q, \dot{q}) + g_i(q) \quad (5)$$

Let the desired angular position of the i^{th} joint be q_{ri} , and define the position and velocity errors as $x_{i1} = q_{ri} - q_i$ and $x_{i2} = \dot{x}_{i1}$, respectively, then the error dynamics can be obtained from (4) as follows:

$$\dot{x}_{i1} = x_{i2} \quad (6)$$

$$\dot{x}_{i2} = -m_{ii}^{-1}u_i + m_{ii}^{-1}d_i \quad (7)$$

where for simplicity, the arguments of time have been omitted. Using the property 1, m_{ii}^{-1} in (7) can be substituted by

$$m_{ii}^{-1} = k_{ii} = k_{ii}^o + \Delta k_{ii} \quad (8)$$

where k_{ii}^o denotes the nominal value of the corresponding parameter and Δk_{ii} represents the time-varying uncertainty. With the property 2 one has

$$|d_i| < b_{i1} + b_{i2}|q_i| + b_{i3}|\dot{q}_i|^2 \quad (9)$$

and without loss of generality, $m_{ii}^{-1}d_i$ in (7) can be substituted by

$$m_{ii}^{-1}d_i = h_{i1}x_{i1} + h_{i2}x_{i2} \quad (10)$$

where $h_{ij} = h_{ij}^o + \Delta h_{ij}$, $j = 1, 2$, and h_{ij}^o and Δh_{ij} represent respectively the nominal value and the time-varying uncertainty of the corresponding parameter. Substituting (8) and (10) into (7) obtains

$$\dot{x}_{i1} = x_{i2} \quad (11)$$

$$\dot{x}_{i2} = h_{i1}x_{i1} + h_{i2}x_{i2} - k_{ii}u_i$$

With the plant dynamics (11), the objective is to develop a physically feasible VSVG controller that is robust and without chattering in the control signal to activate the vibration.

3. THE VARIABLE-STRUCTURE-VARIABLE-GAIN CONTROL

In the VSVG control, the system status is divided into three parts corresponding to the control structures as depicted in Fig. 1. Structures I and II are defined as in the conventional VSS [13]. Structure III, which occurs in the sliding sector, is the variable-gain control.

3.1 The sliding sector

The sliding sector in the VSVG control is defined similar to the boundary layer [1], except $x_{i1}x_{i2} < 0$ is necessary. Let the ideal stable sliding surface of the i^{th} subsystem be described by

$$s_i = c_i x_{i1} + x_{i2}, \quad c_i > 0, \quad i = 1, \dots, n. \quad (12)$$

The boundary surfaces of the sliding sector are obtained by increasing and decreasing the parameters in (12) slightly as

$$s_i^+ = c_i^+ x_{i1} + x_{i2}, \quad c_i^+ > 0, \quad i = 1, \dots, n \quad (13)$$

and

$$s_i^- = c_i^- x_{i1} + x_{i2}, \quad c_i^- > 0, \quad i = 1, \dots, n \quad (14)$$

to obtain the sliding sector $\mathcal{G}_i(t)$ as a region satisfying

$$\mathcal{G}_i(t) = \{s_i^+ s_i^- \leq 0\} \quad (15)$$

Figure 1 shows an example of the surfaces for $s_i = 0$, $s_i^+ = 0$ and $s_i^- = 0$, respectively. Within the sliding sector, the VSVG control goes into the variable-gain structure to adapt the system for uncertainty and disturbance with minimum structure switching, and the bound of state error depends on the design of c_i^+ and c_i^- [6][18].

3.2 The VSVG controller

The VSVG control law is proposed to be

$$u_i = \phi_{i1} x_{i1} + \phi_{i2} x_{i2} + g_i \eta(s_i) \quad (16)$$

where ϕ_{i1} and ϕ_{i2} are switching variables, g_i is a constant and $\eta(\cdot)$ is a function of dead-zone limiter defined as follows:

$$\eta(s_i) = \begin{cases} 1, & s_i \text{ in structure I} \\ 0, & s_i \text{ in structure III (sliding sector)} \\ -1, & s_i \text{ in structure II} \end{cases} \quad (17)$$

When the system remains in structure I or II, the control parameters in (16) are selected to satisfy $s_i \dot{s}_i < 0$ so that the sliding sector is attractive. From (11), (12) and (16), \dot{s}_i and $s_i \dot{s}_i$ can be derived as follows:

$$\begin{aligned} \dot{s}_i &= c_i \dot{x}_{i1} + \dot{x}_{i2} \\ &= c_i x_{i2} + h_{i1} x_{i1} + h_{i2} x_{i2} - k_{ii} u_i \\ &= c_i x_{i2} + h_{i1} x_{i1} + h_{i2} x_{i2} - k_{ii} (\phi_{i1} x_{i1} + \phi_{i2} x_{i2} + g_i \eta(s_i)) \\ &= (-k_{ii} \phi_{i1} + h_{i1}) x_{i1} + (-k_{ii} \phi_{i2} + h_{i2} + c_i) x_{i2} - k_{ii} g_i \eta(s_i) \end{aligned} \quad (18)$$

and

$$s_i \dot{s}_i = (-k_{ii} \phi_{i1} + h_{i1}) s_i x_{i1} + (-k_{ii} \phi_{i2} + h_{i2} + c_i) s_i x_{i2} - k_{ii} g_i s_i \eta(s_i) \quad (19)$$

Therefore the control parameters for structure I and II should be chosen as

$$\phi_{i1} = \begin{cases} \alpha_{i1} > \sup\{h_{i1}/k_{ii}\} & \text{if } x_{i1} s_i > 0 \\ \beta_{i1} < \inf\{h_{i1}/k_{ii}\} & \text{if } x_{i1} s_i < 0 \end{cases} \quad (20)$$

$$\phi_{i2} = \begin{cases} \alpha_{i2} > \sup\{(h_{i2} + c_i)/k_{ii}\} & \text{if } x_{i2} s_i > 0 \\ \beta_{i2} < \inf\{(h_{i2} + c_i)/k_{ii}\} & \text{if } x_{i2} s_i < 0 \end{cases} \quad (21)$$

and

$$g_i = \begin{cases} g_i^+ > 0 & \text{if } k_{ii} > 0 \\ g_i^- < 0 & \text{if } k_{ii} < 0 \end{cases} \quad (22)$$

In the sliding sector, the control law simply becomes

$$u_i = \dot{\phi}_{i1}x_{i1} + \dot{\phi}_{i2}x_{i2} \quad (23)$$

The substitution of (23) into (11) obtains

$$\begin{aligned} \dot{x}_{i1} &= x_{i2} \\ \dot{x}_{i2} &= h_{i1}x_{i1} + h_{i2}x_{i2} - k_{ii}\dot{\phi}_{i1}x_{i1} - k_{ii}\dot{\phi}_{i2}x_{i2} \end{aligned} \quad (24)$$

and

$$\begin{aligned} \frac{\dot{x}_{i2}}{\dot{x}_{i1}} &= \frac{h_{i1}x_{i1} + h_{i2}x_{i2} - k_{ii}\dot{\phi}_{i1}x_{i1} - k_{ii}\dot{\phi}_{i2}x_{i2}}{x_{i2}} \\ &= \frac{(h_{i1} - k_{ii}\dot{\phi}_{i1})x_{i1} + (h_{i2} - k_{ii}\dot{\phi}_{i2})x_{i2}}{x_{i2}} \\ &= (h_{i1} - k_{ii}\dot{\phi}_{i1})\frac{x_{i1}}{x_{i2}} + h_{i2} - k_{ii}\dot{\phi}_{i2} \end{aligned} \quad (25)$$

where $\dot{x}_{i2}/\dot{x}_{i1}$ represents the slope of state trajectory on the phase plane [19], and in the ideal sliding mode, it should be equal to the slope, c_i , of the sliding surface. But physically because of uncertainty, $\dot{x}_{i2}/\dot{x}_{i1}$ will not always be equal to c_i . In other words, the ideal sliding mode control is very difficult to realize in the noisy environment, and therefore in the VSVG control, the state trajectories are relaxed to be within the sliding sector that can satisfy some performance requirements. (25) shows that the slope of the state trajectory is a function of $\dot{\phi}_{i1}$ and $\dot{\phi}_{i2}$. Therefore the slope or equivalently the direction of the state trajectory can be manipulated on-line by adjusting $\dot{\phi}_{i1}$ and $\dot{\phi}_{i2}$. Since in the robot control the angular position, x_{i1} and velocity, x_{i2} are measurable, an appropriate rule is to choose $\dot{\phi}_{i1}$ and $\dot{\phi}_{i2}$ to satisfy

$$\frac{x_{i2}}{x_{i1}} = (h_{i1} - k_{ii}\dot{\phi}_{i1})\frac{x_{i1}}{x_{i2}} + h_{i2} - k_{ii}\dot{\phi}_{i2} \quad (26)$$

so that the state trajectory can be kept within the sliding sector and heading the target state. The turning points of the trajectories a_1, \dots, a_4 in Fig. 2 shows the effects of changing the control law into (23) and satisfying (26). However since the solution pair $(\dot{\phi}_{i1}, \dot{\phi}_{i2})$ of (26) is not unique, one will need an extra constraint to determine the desired parameters. Fortunately (23) represents a combination of a proportional control, $\dot{\phi}_{i1}x_{i1}$, and a derivative control, $\dot{\phi}_{i2}x_{i2}$. The empirical tuning rule of PID controller can help to choose $\dot{\phi}_{i1}$ or $\dot{\phi}_{i2}$, and leave the rest one to be calculated from (26). For simplicity if only the proportional portion is applied, then

$$\dot{\phi}_{i1} = \frac{\left[h_{i1} - \left(\frac{x_{i2}}{x_{i1}} - h_{i2} \right) \frac{x_{i2}}{x_{i1}} \right]}{k_{ii}}, \quad \text{and } \dot{\phi}_{i2} = 0 \quad (27)$$

where h_{i1} , h_{i2} , and k_{ii} are defined as above and rewritten as follows:

$$h_{i1} = h_{i1}^o + \Delta h_{i1}, \quad h_{i2} = h_{i2}^o + \Delta h_{i2} \quad \text{and} \quad k_{ii} = k_{ii}^o + \Delta k_{ii} \quad (28)$$

3.3 Perturbations estimation

From (18), we can obtain

$$\frac{\partial \dot{s}_i}{\partial h_{i1}} = x_{i1}, \quad \frac{\partial \dot{s}_i}{\partial h_{i2}} = x_{i2} \quad \text{and} \quad \frac{\partial \dot{s}_i}{\partial k_{ii}} = -u_i \quad (29)$$

and the uncertainty can be described as

$$\partial h_{i1} = \frac{\partial \dot{s}_i}{x_{i1}}, \quad \partial h_{i2} = \frac{\partial \dot{s}_i}{x_{i2}}, \quad \text{and} \quad \partial k_{ii} = -\frac{\partial \dot{s}_i}{u_i} \quad (30)$$

For small sampling intervals, (30) can be approximately represented by

$$\Delta h_{i1} = \frac{\Delta \dot{s}_i}{x_{i1}}, \Delta h_{i2} = \frac{\Delta \dot{s}_{im}}{x_{i2}}, \text{ and } \Delta k_{ii} = \frac{\Delta \dot{s}_i}{u_i} \quad (31)$$

and $\Delta \dot{s}_i$ is calculated as follows:

$$\dot{s}_i(t) \equiv \frac{s_i(t) - s_i(t-1)}{\Delta t} \quad (32)$$

$$\begin{aligned} \Delta \dot{s}_i(t) &= \dot{s}_i(t) - \dot{s}_i(t-1) \equiv \frac{s_i(t) - s_i(t-1)}{\Delta t} - \frac{s_i(t-1) - s_i(t-2)}{\Delta t} \\ &= \frac{s_i(t) - 2s_i(t-1) + s_i(t-2)}{\Delta t} \end{aligned} \quad (33)$$

where Δt denotes the sampling interval.

Theorem 1: The uncertain system described by (11) with the sliding sector (15) and the control law (16) satisfying

$$\phi_{i1} = \begin{cases} \alpha_{i1} > \sup \left\{ \frac{h_{i1}}{k_{ii}} \right\} & \text{if } x_{i1} s_i^+ > 0 \\ \gamma_{i1} = \left[\frac{h_{i1} - \left(\frac{x_{i2}}{x_{i1}} - h_{i2} \right) \frac{x_{i2}}{x_{i1}}}{k_{ii}} \right] & \text{if } s_i^+ s_i^- \leq 0 \\ \beta_{i1} < \inf \left\{ \frac{h_{i1}}{k_{ii}} \right\} & \text{if } x_{i1} s_i^- < 0 \end{cases} \quad (34)$$

$$\phi_{i2} = \begin{cases} \alpha_{i2} > \sup \left\{ \frac{(h_{i2} + c_i)}{k_{ii}} \right\} & \text{if } x_{i2} s_i^- > 0 \\ \gamma_{i2} = 0 & \text{if } s_i^+ s_i^- \leq 0 \\ \beta_{i2} < \inf \left\{ \frac{(h_{i2} + c_i)}{k_{ii}} \right\} & \text{if } x_{i2} s_i^+ < 0 \end{cases} \quad (35)$$

and

$$g_i = \begin{cases} g_i^+ > 0 & \text{if } k_{ii} > 0 \\ g_i^- < 0 & \text{if } k_{ii} < 0 \end{cases} \quad (36)$$

is asymptotically stable.

Proof: Consider the Lyapunov function

$$v_i = \frac{1}{2} s_i^2 \quad (37)$$

Differentiating v_i with respect to time and using (19), we obtain

$$\begin{aligned} \dot{v}_i &= s_i \dot{s}_i \\ &= (-k_{ii} \phi_{i1} + h_{i1}) s_i x_{i1} + (-k_{ii} \phi_{i2} + h_{i2} + c_i) s_i x_{i2} - k_{ii} g_i s_i \eta(s_i) \end{aligned} \quad (38)$$

Applying (34)-(36) for control structures I and II, and refers to the phase plane distribution as shown in Fig. 3 the three terms on the right side of (38) satisfy the following inequalities:

$$\begin{aligned} \text{if } s_i^+ x_{i1} > 0 \text{ then } s_i x_{i1} > 0, \phi_{i1} = \alpha_{i1} > \sup \left\{ \frac{h_{i1}}{k_{ii}} \right\} &\Rightarrow -k_{ii} \phi_{i1} + h_{i1} < 0 \\ \text{if } s_i^- x_{i1} < 0 \text{ then } s_i x_{i1} < 0, \phi_{i1} = \alpha_{i1} < \inf \left\{ \frac{h_{i1}}{k_{ii}} \right\} &\Rightarrow -k_{ii} \phi_{i1} + h_{i1} > 0 \\ \Rightarrow (-k_{ii} \phi_{i1} + h_{i1}) s_i x_{i1} < 0 & \end{aligned} \quad (39)$$

$$\begin{aligned} \text{if } s_i^- x_{i2} > 0, \text{ then } s_i x_{i2} > 0, \phi_{i2} = \alpha_{i2} > \sup[(h_{i2} + c_i) / k_{ii}] &\Rightarrow (-k_{ii}\phi_{i2} + h_{i2} + c_i) < 0 \\ \text{if } s_i^+ x_{i2} < 0, \text{ then } s_i x_{i2} < 0, \phi_{i2} = \beta_{i2} < \inf[-(h_{i2} + c_i) / k_{ii}] &\Rightarrow (-k_{ii}\phi_{i2} + h_{i2} + c_i) > 0 \\ \Rightarrow (-k_{ii}\phi_{i2} + h_{i2} + c_i) s_i x_{i2} < 0 & \end{aligned} \quad (40)$$

$$-k_{ii} g_i s_i \eta(s_i) = -k_{ii} g_i |s_i|, k_{ii} > 0, g_i^+ > 0, k_{ii} < 0, g_i^- < 0 \Rightarrow -k_{ii} g_i |s_i| < 0 \quad (41)$$

In the sliding sector, we have

$$s_i^+ s_i^- \leq 0 \text{ and } \phi_{i1} = \gamma_{i1} = \frac{\left[h_{i1} - \left(\frac{x_{i2}}{x_{i1}} - h_{i2} \right) \frac{x_{i2}}{x_{i1}} \right]}{k_{ii}}$$

Rearrange (26) to obtain

$$\frac{x_{i2}^2}{x_{i1}} = (h_{i1} - k_{ii}\phi_{i1})x_{i1} + (h_{i2} - k_{ii}\phi_{i2})x_{i2} \quad (42)$$

In the sliding sector, (38) can be rewritten as

$$s_i \dot{s}_i = s_i [(h_{i1} - k_{ii}\phi_{i1})x_{i1} + (h_{i2} - k_{ii}\phi_{i2})x_{i2} + c_i x_{i2}] \quad (43)$$

The substitution of (42) into (43) gives

$$\begin{aligned} \dot{s}_i &= s_i \dot{s}_i = s_i \left[\frac{x_{i2}^2}{x_{i1}} + c_i x_{i2} \right] \\ &= s_i \left[\frac{x_{i2}(c_i x_{i1} + x_{i2})}{x_{i1}} \right] = s_i^2 \left[\frac{-x_{i2}}{x_{i1}} \right] < 0 \end{aligned} \quad (44)$$

where since in the sliding sector $x_{i1}x_{i2} < 0$ is a necessity and therefore $(x_{i2}/x_{i1}) < 0$ is obvious. (39) through (44) show that $s_i \dot{s}_i < 0$ is always satisfied and the system is asymptotically stable.

4. EXPERIMENT OF VSVG ROBOT CONTROL

Figure 4 depicts a photo of the experimental system, Fig. 5 is its schematic diagram and Fig. 6 shows a block diagram of the whole system. The robot of the experiment has five-degree of freedom and its parameters are unknown. Photo encoders measure the joint positions, and F/V units and a 12-bits A/D converter measure the velocity. A feedforward force is applied to eliminate the effect of friction and dead zone [14]. Since joints 1 and 2 response most significantly to the load perturbations and variations of the associated parameters. The experiments were simply conducted for them. Figure 7 shows the step responses of joint 1 subject to variant input levels and attitudes of the robot for identifying its nominal and uncertain values of the parameter [18]. The characteristics of joint 2 were tested in a similar way. With the testing results, the error dynamics with respect to joints 1 and 2 were obtained respectively as:

$$\begin{aligned} \text{Joint 1 } \quad x_{11} &= x_{12} \\ x_{12} &= 0x_{11} - (25 \pm 8)x_{12} - (380 \pm 60)u_1 \end{aligned} \quad (45)$$

$$\begin{aligned} \text{Joint 2 } \quad x_{21} &= x_{22} \\ x_{22} &= 0x_{21} - (20 \pm 5)x_{22} - (350 \pm 50)u_2 \end{aligned} \quad (46)$$

where $x_{i1} = q_{ri} - q_i$, q_{ri} and q_i denote the desired and actual outputs of the i^{th} joint, respectively. The robot system was then investigated for conventional VSS control, boundary layer approach and the proposed VSVG control, respectively. With the error dynamics described by (45) and (46), and c_i , c_i^+ and c_i^- , $i=1, 2$

being chosen as 20, 18, and 25, the associated parameters in (34)-(36) of the VSVG controller for structures I and II (conventional VSS) are obtained as

$$\alpha_{11} = 2.2, \beta_{11} = -2.2, \alpha_{12} = 0.02, \beta_{12} = -0.02, g_1^+ = 0.4, g_1^- = -0.4$$

$$\alpha_{21} = 2.2, \beta_{21} = -2.2, \alpha_{22} = 0.02, \beta_{22} = -0.02, g_2^+ = 0.4, g_2^- = -0.4$$

, and in the sliding sector, γ_{11} and γ_{21} are calculated on-line subject to (27) or $\gamma_{12} = \gamma_{22} = 0$.

The experimental results of joint 1 and 2 are shown in Figs. 8-9. Here the angular positions refer to the corresponding joints and the gear ratio is 240 for both joint 1 and 2. For conventional VSS control, Fig. 8 shows that, in the transient state, the chattering and high control gain is obvious. For the VSVG control, Fig. 9 depicts that the chattering is alleviated effectively and the steady state error is small. The chattering is not significant, the high control gain does not appear and small steady state position error is obtained. Comparing the spectrum of the control signals with those obtained by the conventional VSS control, the VSVG method contributes to use the low frequency part.

5. CONCLUSION

A VSVG controller that can efficiently alleviate the difficulties of chattering and high gain control has been successfully developed for the motion control of robot manipulators. The VSVG control system has been proved theoretically to be asymptotically stable subject to constrained uncertain conditions and experiments of a robot control system have verified this. The computation burden of the control algorithm is light and suitable for physical implementation. The experimental system of robot control has demonstrated the feasibility and effectiveness of the VSVG controller. The proposed variable-gain structure that occurs in the sliding sector can only be realized by systems with state feedback. Therefore the availability of state variables either measured or obtained by using an observer is a necessity of the VSVG control. Fortunately for most motion control systems the position, velocity and even acceleration are usually measurable so that VSVG control is a candidate for robust control of this class of systems.

6. REFERENCES

- [1] J. J. Slotine, S. S. Sastry, "Tracking control of nonlinear systems using sliding surface, with application to robot manipulators", *INT. J. Control*, vol.38, no. 2, pp. 465-492, 1983.
- [2] W. H. Zhu, H. T. Chen, Z. J. Zhang, "A variable structure robot control algorithm with an observer", *IEEE Trans. Robotics and Automation*, vol. 8, no. 4, pp. 486-492, 1992.
- [3] T. P. Leung, Q. J. Zhou, C. Y. Su, "An adaptive variable structure model following control design for robot manipulators", *IEEE Trans. Automatic Control*, vol. 36, no. 3, pp. 347-353, 1991.
- [4] K. S. Yeung, Y. P. Chen, "A new controller design for manipulator using the theory of variable structure systems", *IEEE Trans. Automatic Control*, vol. 33, no. 2, pp. 200-206, 1988.
- [5] M. Z., M. P., "An improved variable structure model-following control for robotic manipulators", *Int. J. Adaptive Control and Signal Processing*, vol. 7, pp. 539-562, 1993.
- [6] T. L. Chern, J. S. Wong, "DSP based integral variable structure control for DC motor servo drivers", *IEE Proc. Control Theory Appl.* vol. 142, no. 5, pp. 444-450, 1995.
- [7] J. J. E. Slotine, W. Li, "Applied nonlinear control", *Prentice-Hall*, 1991.

- [8] F. J. Chen, "Tracking control of dc motors via an improved chattering alleviation control", *IEEE Trans. Industrial Electronics*, vol. 39, no. 1, pp. 25-29, 1992.
- [9] F. J. Chen, "Position control of dc motors via variable structure systems control: a chattering alleviation approach", *IEEE Trans. Industrial Electronics*, vol. 37, no. 6, pp. 452-459, 1990.
- [10] D. Driankov, H. Hellendoorn, M.Reinfrank, "An introduction to fuzzy control", Springer Verlag, 1993.
- [11] L. K. Wong, F. H. F. Leung, P. K. S. Tam, "Lyapunov-function-based design of fuzzy logic controllers and its application on combining controllers", *IEEE Trans. Industrial Electronics*, vol. 45, no. 3, pp. 502-509, 1998.
- [12] J. C. Chiou, "Robust control of non-linear dynamic systems using sliding mode control and productive networks", *Proc. Automatic Control Conf.*, pp. 4231-4235, 1995.
- [13] K. K. D. Young, "Controller design for a manipulator using theory of variable structure systems", *IEEE Trans. Syst., Man, Cybern.*, vol. SMC-8, no. 2, pp.101-109, 1978.
- [14] K. S. Fu, R.C. Gonzalez, C.S.G. Lee, "ROBOTICS: control, sensing, vision, and intelligence", McGRAW-Hill, 1987.
- [15] R. Ortega, M.W. Spong, "Adaptive motion control of rigid robots: a tutorial", *Proc. 28th Conf. on Decision and Control, IEEE*, New York, pp. 1575-1584, 1989.
- [16] S. N. Singh, "Adaptive model following control of nonlinear robotic systems", *IEEE Trans. Automatic Control*, AC-30, pp. 1099-1100, 1985.
- [17] M. Zhihong, M. Palaniswami, "A robust decentralized three-segment non-linear sliding mode control for rigid robotic manipulators", *Int. J. of Adaptive Control and Signal Processing*, vol. 9, pp. 443-457, 1995.
- [18] N. S. Nise, "Control system engineering", Benjamin/Cummings, 1997.
- [19] I. J. Nagrath, M.Gopal, "Control system engineering", Wiley eastern limited, 1982.

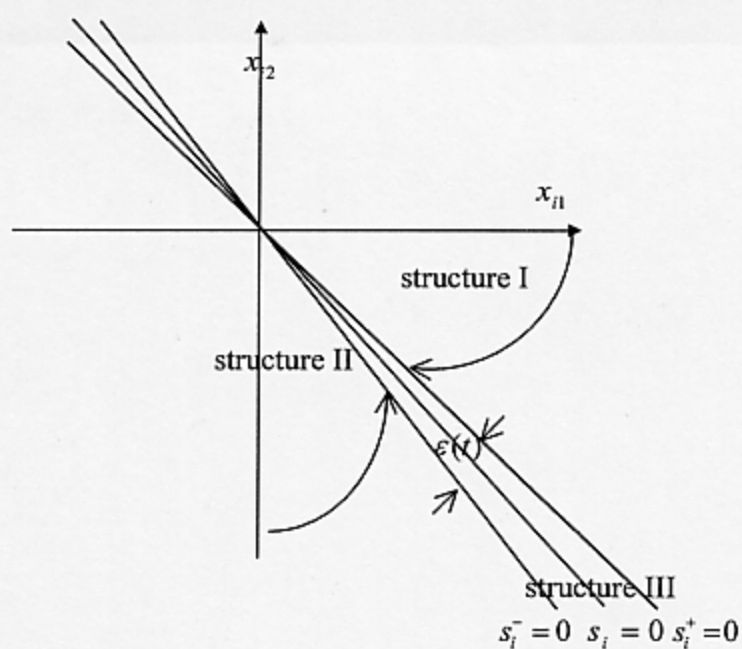

Fig. 1 The schematic of sliding sector of VSVG approach

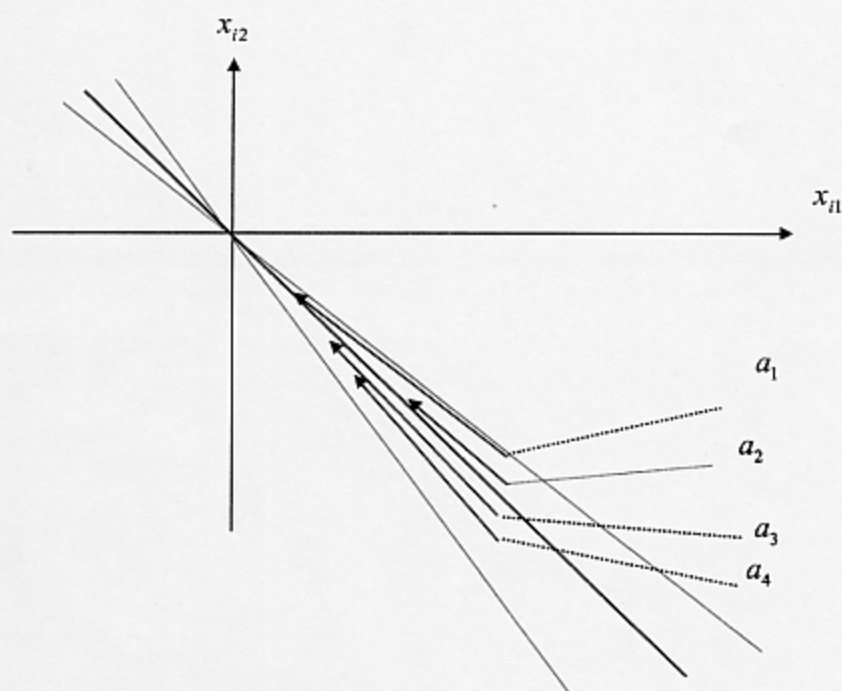
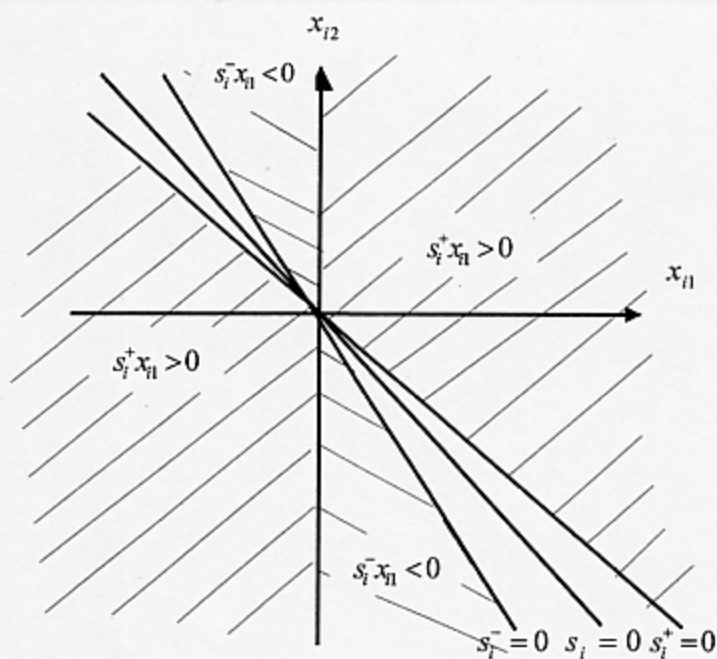
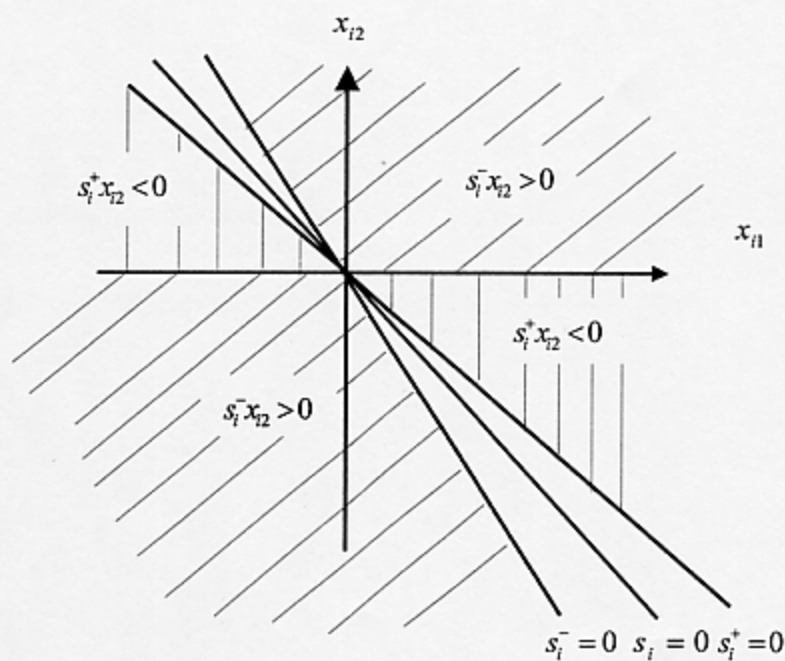

Fig. 2 The desired moving direction in the sliding sector for different sample point

Fig. 3(a) Phase plane distribution of $s_i^+ x_{i1} > 0$ and $s_i^- x_{i1} < 0$ Fig. 3(b) Phase plane distribution of $s_i^+ x_{i2} < 0$ and $s_i^- x_{i2} > 0$

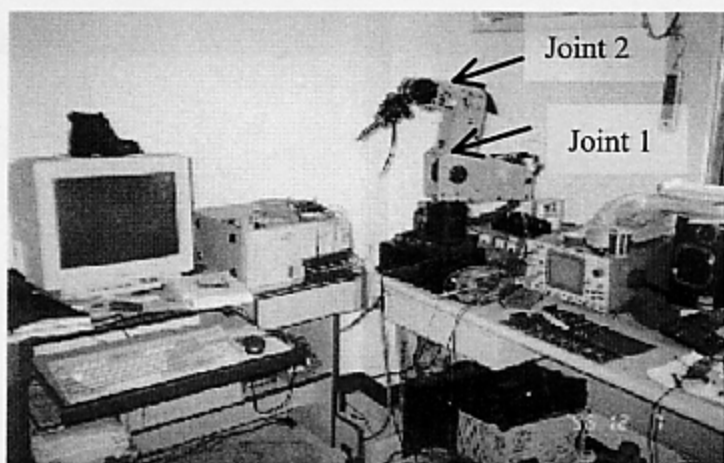

Fig. 4 The DC servo control system with large perturbation

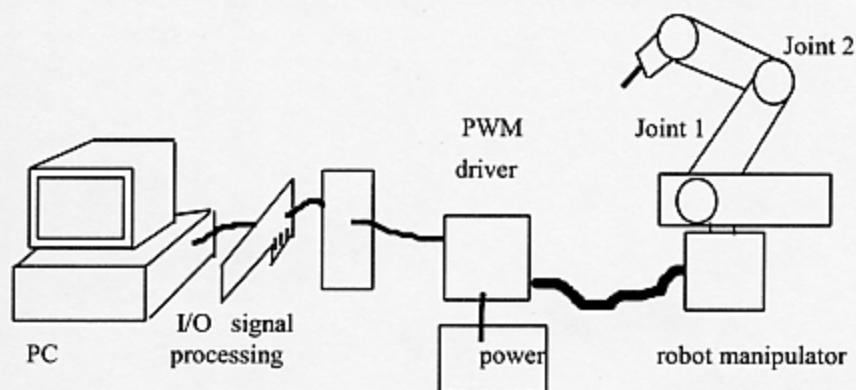

Fig. 5 Schematic diagram of Fig. 3

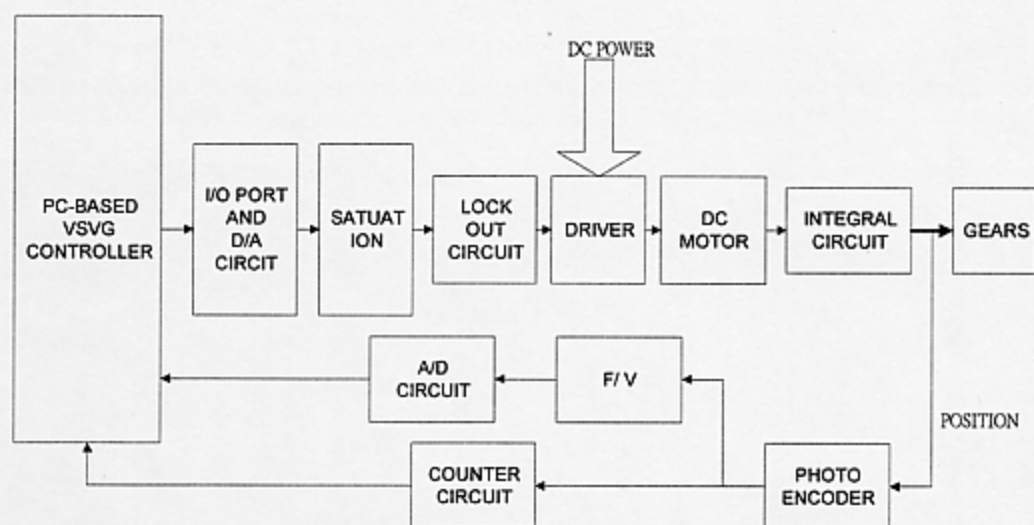

Fig. 6 Block diagram for PC-based VSVG DC servo control system

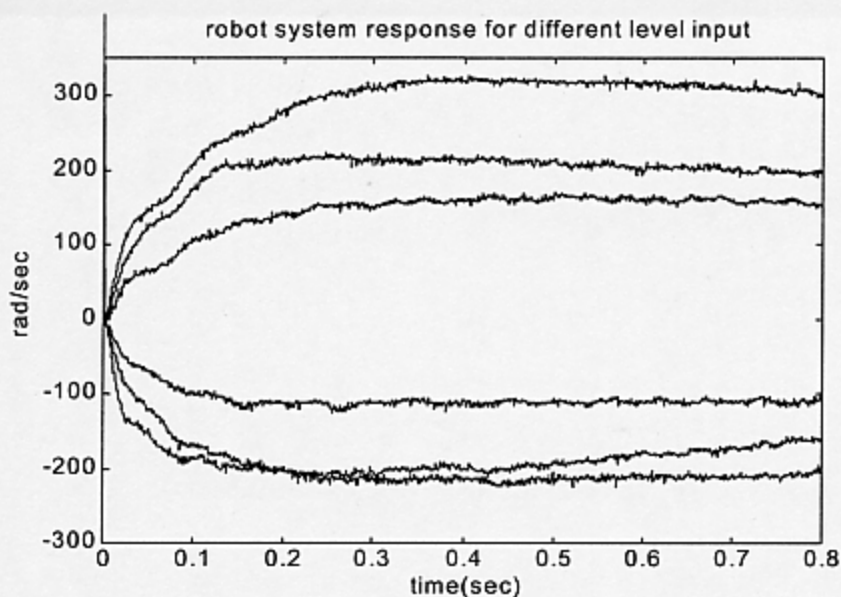
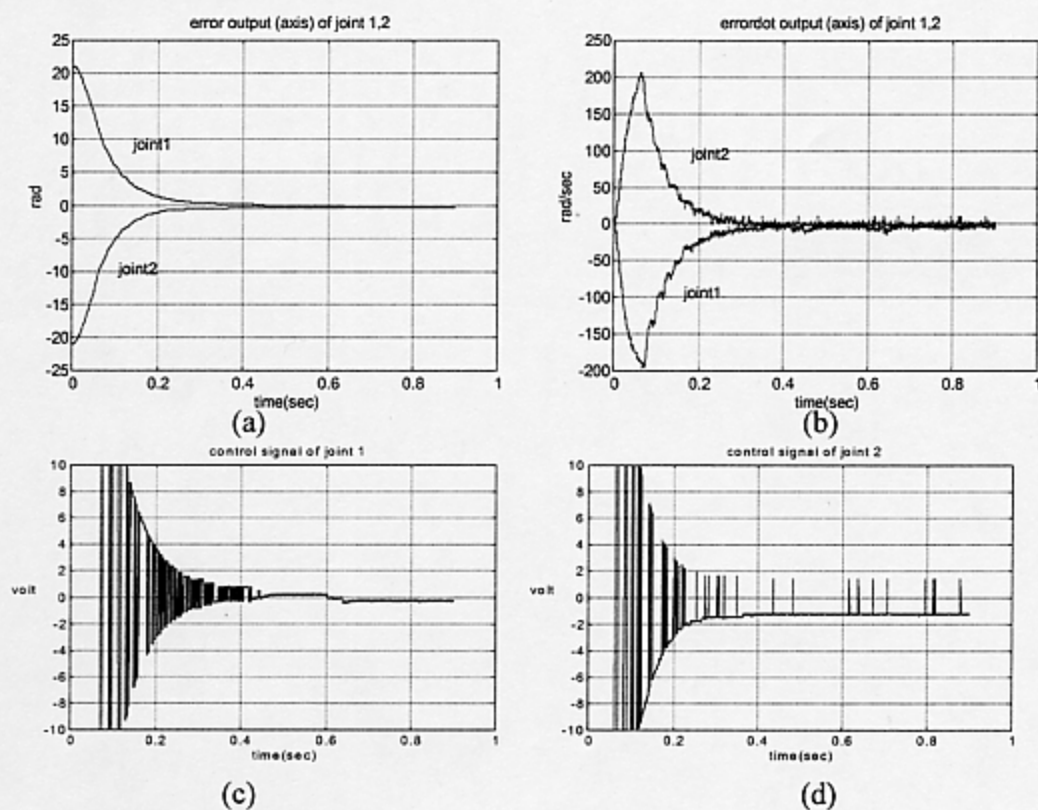

Fig. 7 Open loop step responses for different input levels of joint 1

EXPERIMENTAL RESULTS



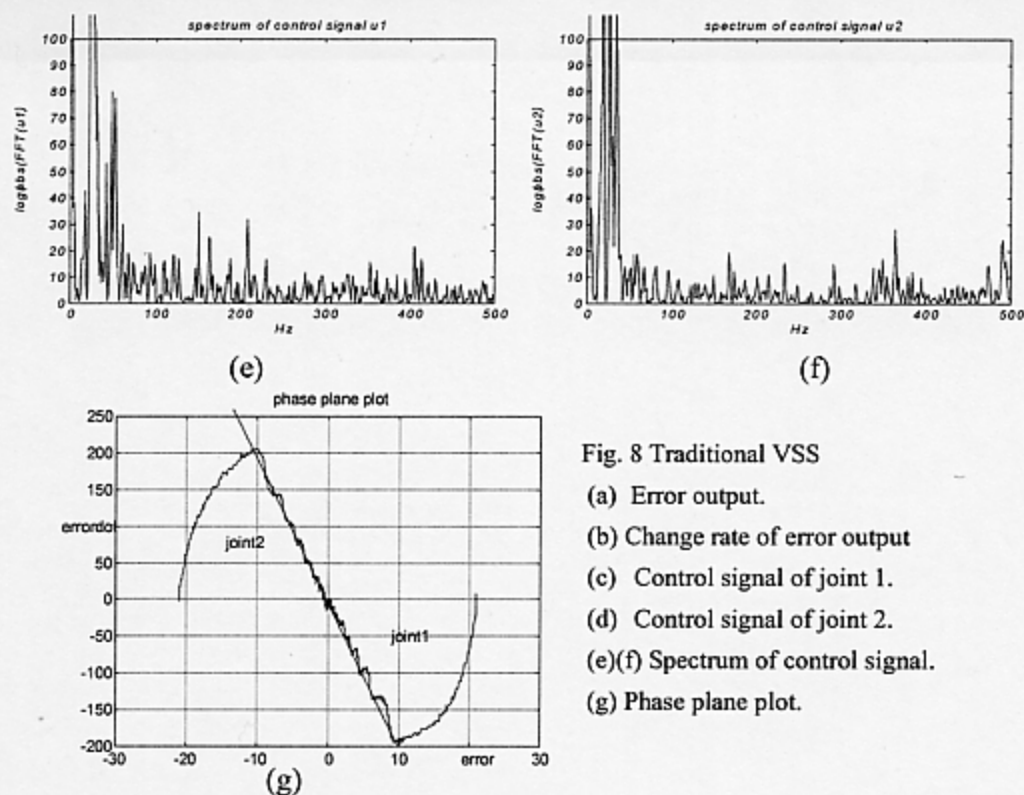
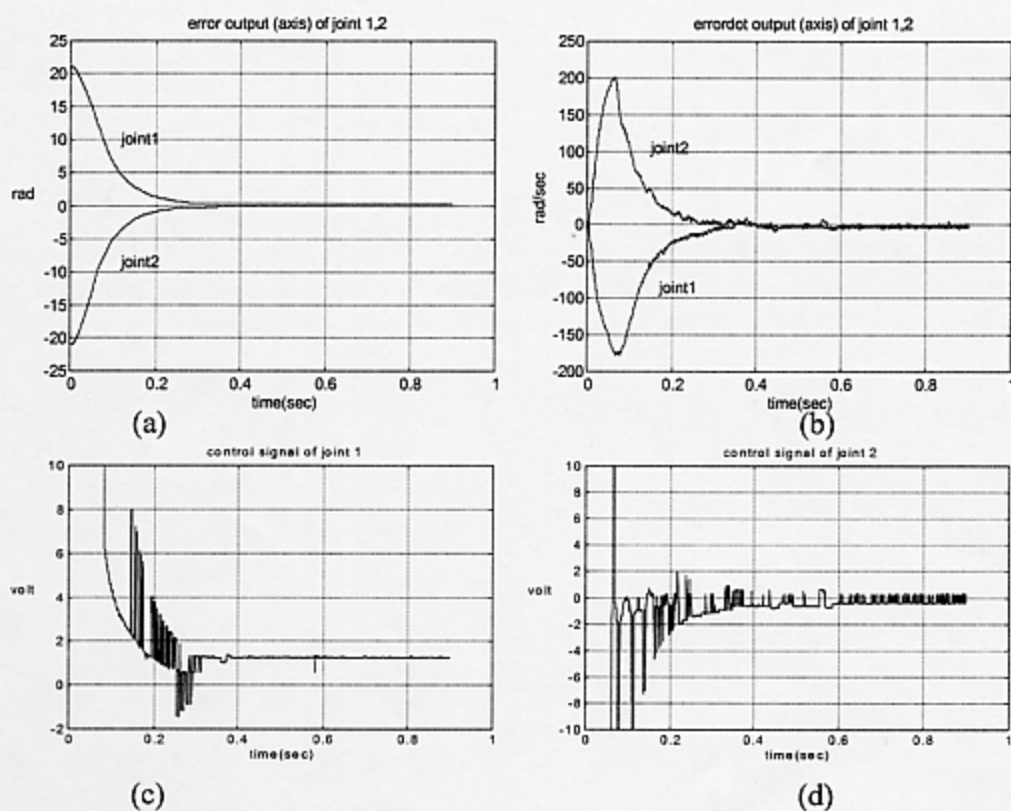
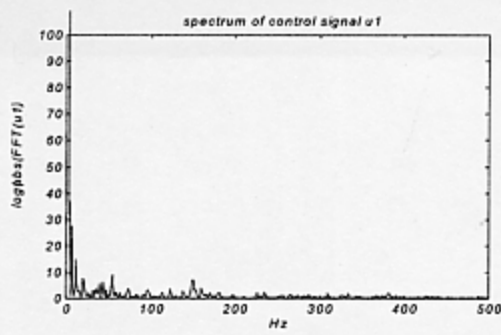

Fig. 8 Traditional VSS

- (a) Error output.
- (b) Change rate of error output
- (c) Control signal of joint 1.
- (d) Control signal of joint 2.
- (e)(f) Spectrum of control signal.
- (g) Phase plane plot.





(e)

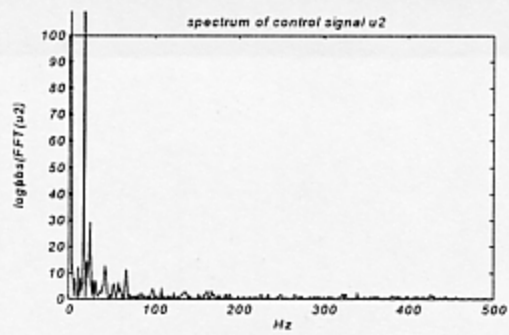

(f)

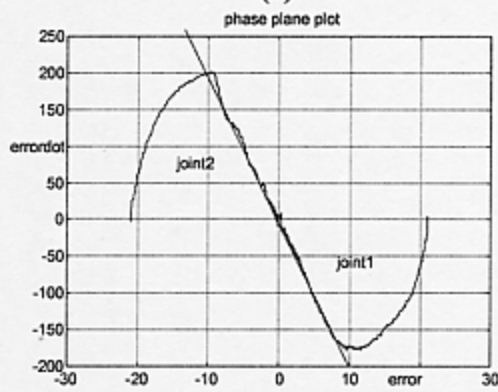

(g)

Fig. 9 VSVG approach

- (a) Error output.
- (b) Change rate of error output.
- (c) Control signal of joint 1.
- (d) Control signal of joint 2
- (e) (f) Spectrum of control signal
- (g) Phase plane plot.

