



Tuning PI/PID controllers for integrating processes with deadtime and inverse response by simple calculations

Neng-Sheng Pai^a, Shih-Chi Chang^b, Chi-Tsung Huang^{b,*}

^a Department of Electrical Engineering, National Chin-Yi University of Technology, Taiping, Taichung 41111, Taiwan

^b Department of Chemical and Materials Engineering, Tunghai University, Taichung 40704, Taiwan

ARTICLE INFO

Article history:

Received 2 December 2009

Received in revised form 2 April 2010

Accepted 2 April 2010

Keywords:

Direct synthesis PID tuning

Regulatory control

Minimum IAE searching

Boiler level control

ABSTRACT

A simple calculation method of a practical PI/PID controller tuning for integrating processes with deadtime and inverse response based on a model is presented in this study. First, analytical expressions for PI/PID controller settings based on the model using a direct synthesis method for disturbance rejection (DS-d) are employed. Next, optimum tuning parameter (λ) for DS-d based on the model and minimum IAE criterion are obtained via the golden-section searching technique. These optimum λ data are then empirically correlated into two equations. Thus, PI/PID controller settings for the model can easily be obtained from the parameter λ using DS-d formulas. The advantage of the proposed method is that DS-d PI/PID settings could be expediently sought by simple calculations using these equations without any tedious design. Simulation results have demonstrated that the proposed tuning technique can perform better for load/disturbance changes than other available methods in the literature.

© 2010 Elsevier Ltd. All rights reserved.

1. Introduction

The integrating process, whose dynamics also possess both deadtime and inverse response characteristics, is of particular interest. However, it is difficult to control. Besides inverse response characteristic, if a bounded step disturbance is entered to the process input, its effect on the output is usually unbounded, as shown in Fig. 1. The classic example of such process dynamics has been observed in a boiler steam drum, in which the feed water to the boiler is manipulated to control its level. Although drum-type boilers are quite popular in process industries, it is somewhat surprising that the development of the control on such dynamics seem to be relatively scarce in the literature. Åström and Bell [1] recently proposed a nonlinear dynamic model for natural circulation drum-boilers from first principles. Kim and Chio [2] also presented a boiler level dynamic model, which is based on conservation rules of mass, momentum, and energy, together with constitutional equations. However, for practical control purposes, an approximated dynamic model instead of a complex rigorous model for boiler steam drum is generally required. Luyben [3] recommended using an open-loop transfer-function model for the process dynamics as:

$$G_p(s) = \frac{K_p(-\tau_a s + 1)e^{-\theta s}}{s(\tau s + 1)} \quad (1)$$

A model identification procedure based on open-loop step-response data using Matlab software is also presented. In addition, Luyben [3] proposed a frequency-domain PI/PID controller tuning technique using Matlab software. This method, however, requires solving simultaneous nonlinear algebraic equations to find a reset time (τ_I). Then, it iteratively finds a controller gain (K_C) that gives a maximum peak in the closed-loop servo log modulus curve of +2 dB. Fundamentally, Luyben's method [3] is a servo-control approach, and computer software (such as Matlab) is generally required for solving these complex numerical problems.

On the other hand, the direct synthesis (DS) design method, which is one kind of model-based approaches, allows the control system designer to specify the desired closed-loop behavior directly from the process model. Chen and Seborg [4] have pointed out that most DS approaches in the literature are usually based on the desired closed-loop transfer function for set-point changes. Consequently the resulting DS controllers tend to perform well for set-point changes, but the load/disturbance response might not be satisfactory. However, for many process control applications, such as boiler level control, load/disturbance rejection is more important than set-point tracking. Chen and Seborg [4], therefore, investigated disturbance problem and developed a novel direct synthesis design for disturbance rejection, which is denoted as DS-d. In addition, Chen and Seborg [4] also derived several DS-d analytical expressions for PI/PID controllers based on some common types of process models. Meanwhile, the DS controllers normally need a single tuning parameter, the desired closed-loop time constant (λ). The λ -tuning method was originally proposed by Dahlin [5], in which an appropriate λ is on-line chosen, and is widely used in the

* Corresponding author. Tel.: +886 4 2359 0262x113; fax: +886 4 2359 0009.
E-mail address: huangct@thu.edu.tw (C.-T. Huang).

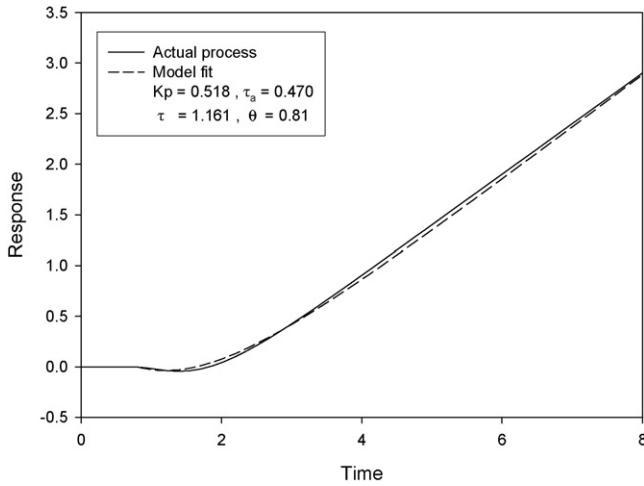

Fig. 1. Open-loop step response of the integrator process with inverse response.

process industries. However, to find an optimum λ using on-line trial-and-error method sometimes may not so adequate for plant engineers. Still, there is no guideline for selecting an appropriate λ value for DS-d design in the literature.

Furthermore, the proportional-integral-derivative (PID) controller remains the widely used controller in the process industries because it is robust and is easy to operate. For a feedback control system, one normally obtains the optimum PID controller settings based on a process model. Smith and his colleagues [6] developed optimum PID controller settings for the first-order-plus-dead-time model based on various integral criteria using time-domain optimization approach. Controller settings can easily be calculated from the model parameters via some empirical formulas. Lately, Huang and his colleagues [7,8] developed optimum tuning formulas using the similar method for open-loop unstable process models and the second-order-plus-dead-time model. They [7,8] also employed an anti-reset-windup PID control algorithm and more complex empirical formulas. Moreover, if the model parameters of the process are specified, each PID parameter is a function of λ in DS-d design [4]. Thus, optimum λ , instead of PID parameters, can be obtained from the model parameters in the DS-d calculations using the previous optimum searching techniques [6–8]. Accordingly, the study tries to find an optimum λ for DS-d PID controller settings based on the model of Eq. (1) via some empirical formulas using previous techniques [6–8].

This paper is organized as follows. Section 2 presents the DS-d formulations for the model. Section 3 develops tuning relationships for finding optimum λ data based on the minimum IAE criterion. An anti-reset-windup PID control algorithm is employed. These optimum λ data are then correlated into two equations: one for PID and the other for PI settings. Three simulation examples are presented in Section 4, where the proposed tuning technique is compared with Luyben’s tuning method [3]. Finally, in Section 5, discussion and conclusions are conducted.

2. Direct synthesis design for load/disturbance rejection (DS-d)

Consider the standard block diagram of the feedback control system shown in Fig. 2. The closed-loop transfer function for load/disturbance rejection is

$$\frac{Y}{L} = \frac{G_I(s)}{1 + G_p(s)G_c(s)} \quad (2)$$

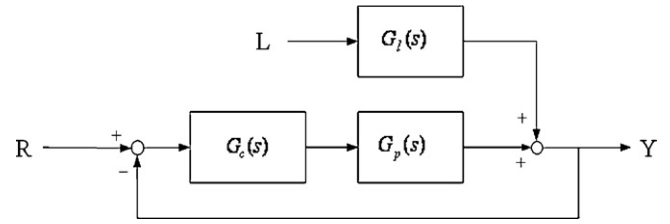

Fig. 2. Block diagram of a simple feedback control system.

If the desired closed-loop transfer function for load/disturbance rejection, $(Y/L)_d$, and the nominal process models, i.e. $\tilde{G}_p(s)$ and $\tilde{G}_I(s)$, are all available. The direct synthesis controller $G_c(s)$ for load/disturbance rejection (DS-d) then becomes

$$G_c(s) = \frac{\tilde{G}_I(s)}{(Y/L)_d \tilde{G}_p(s)} - \frac{1}{\tilde{G}_p(s)} \quad (3)$$

Using a truncated power-series expansion and/or the first-order Pade approximation in Eq. (3), Chen and Seborg [4] developed analytical DS-d PI/PID relations for several process models by assuming $\tilde{G}_I(s) = \tilde{G}_p(s)$ and an ideal PID controller, i.e.

$$G_c(s) = K_c \left(1 + \frac{1}{\tau_I s} + \tau_D s \right) \quad (4)$$

We have tried to use the method of Chen and Seborg [4] to develop DS-d PID analytical expressions for Eq. (1) in this study. The results, however, are not so straightforward, since redundant equations are met. On the other hand, if the term $(1 - \tau_a s)$ in Eq. (1) is approximated to a dead time by a truncated power-series expansion, i.e. $1 - \tau_a s \approx e^{-\tau_a s}$, Eq. (1) then becomes

$$G_p(s) = \frac{K_p(-\tau_a s + 1)e^{-\theta s}}{s(\tau s + 1)} \approx \frac{K_p e^{-(\tau_a + \theta)s}}{s(\tau s + 1)} = \frac{K_p e^{-\theta_a s}}{s(\tau s + 1)} \quad (5)$$

where θ_a is a redefined time delay, and $\theta_a = \tau_a + \theta$. Since analytical DS-d PID expressions of the last transfer function of Eq. (5) have already been developed by Chen and Seborg [4], one therefore can use them for Eq. (1) in this study. Furthermore, the specified closed-loop transfer function for Eq. (5) proposed by Chen and Seborg [4] is

$$\left(\frac{Y}{L} \right)_d = \frac{K_d s e^{-\theta_a s}}{(\lambda s + 1)^3} \quad (6)$$

where λ is the closed-loop time constant, and $K_d = \tau_I / K_c$. Accordingly, the DS-d PID tuning relations [4] for the studied model of Eq. (1) can be approximated as:

$$K_c = \frac{(\tau + \theta + \tau_a)(3\lambda + \theta + \tau_a)}{K_p(\lambda + \theta + \tau_a)^3} \quad (7)$$

$$\tau_I = 3\lambda + \theta + \tau_a \quad (8)$$

$$\tau_D = \frac{3(\theta + \tau_a)\tau\lambda + (\theta + \tau_a)^2\tau - \lambda^3 + 3\tau\lambda^2}{(3\lambda + \theta + \tau_a)(\theta + \tau_a + \tau)} \quad (9)$$

From the above equations, it is apparent that λ is the only parameter for PID settings when the model parameters (i.e., K_p , τ_a , τ and θ) are given.

3. Development of tuning relationships

3.1. Tuning for PID controller

Although the developed PID relations based on DS-d [4] in Eqs. (7)–(9) are not exactly analytical results, since several approximations are assumed, they are quite useful. The controller tuning requires only a single tuning parameter, i.e. the desired closed-loop time constant (λ). However, it looks that there is no guideline for

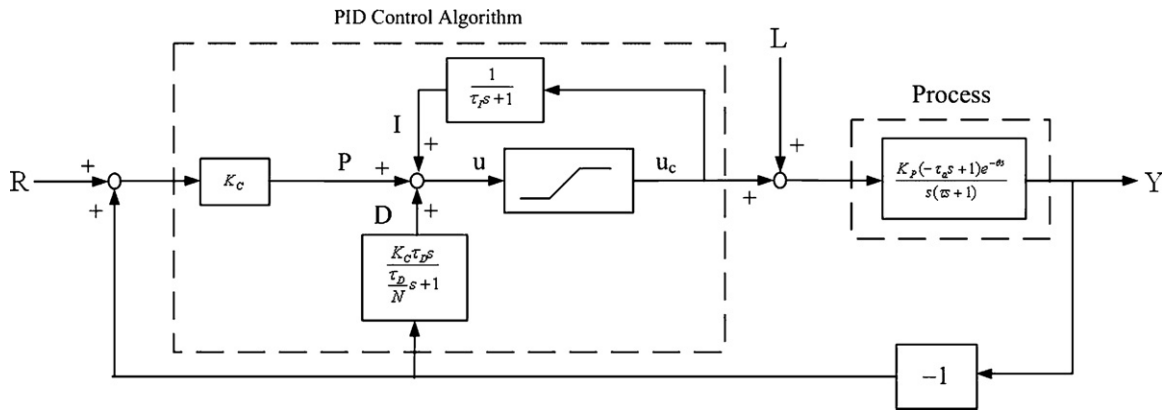

Fig. 3. Block diagram of the PID control system considered.

selecting an appropriate λ value for Eqs. (7)–(9) in the literature. Furthermore, finding an appropriate λ by on-line trial-and-error is not so adequate in practice. This study tries to find an optimum λ based on the model parameters of Eq. (1) by computer searching. Thus, appropriate PID settings can be calculated from Eqs. (7)–(9).

In order to develop practical PID tuning relations, $G_I(s) = G_p(s)$ in Fig. 2 is assumed throughout this study, which is similar to Chen and Seborg [4]. In addition, a practical PID control algorithm dubbed the reset-feedback form of PID controller is chosen. The feedback control system shown in Fig. 2, therefore, becomes a configuration of Fig. 3, which is the system considered in this study. As shown in Fig. 3, the reset-feedback PID algorithm can be described as:

$$u_c(t) = \begin{cases} 1 & \text{for } u(t) > 1 \\ u(t) & \text{for } -1 \leq u(t) \leq 1 \\ -1 & \text{for } u(t) < -1 \end{cases} \quad (10)$$

where

$$u(t) = P(t) + I(t) + D(t) \quad (11)$$

and

$$P(t) = K_c e(t) \quad (12)$$

$$\tau_I \frac{dI(t)}{dt} + I(t) = u_c(t) \quad (13)$$

$$\tau_D \frac{dD(t)}{dt} + D(t) = -K_c \tau_D \frac{dy(t)}{dt} \quad (14)$$

The above PID control algorithm avoids ‘derivative kick’ and provides noise filter. Without loss of generality, the noise filtering constant N is fixed, and $N=10$ is used throughout the study [9]. In addition, a saturation function ($-1 \leq u_c \leq 1$) with anti-reset windup compensation is also considered. It should be noted that the anti-reset windup compensation is a necessary part for industrial PID controllers. Furthermore, Smith and Corripio [10] have pointed out: “Reset windup protection is an option that must be bought in analogy controllers. It is a standard feature in any computer-based controller.” Details of this PID control algorithm can be found elsewhere [9–12]. Such kind of control study using the reset-feedback PID controller is considered to be more realistic for a practical situation.

Moreover, for the purpose of expressing the process model and controller in general, we consider that the transfer functions of process model and controller are represented as dimensionless in this study. Let $\hat{s} = s\tau$ as dimensionless Laplace-transformed variable, the process model in Eq. (1) can, therefore, be represented as

$$G_p(\hat{s}) = \frac{K_p \tau (-\hat{\tau}_a \hat{s} + 1) e^{-\hat{\theta} \hat{s}}}{\hat{s}(\hat{s} + 1)} \quad (15)$$

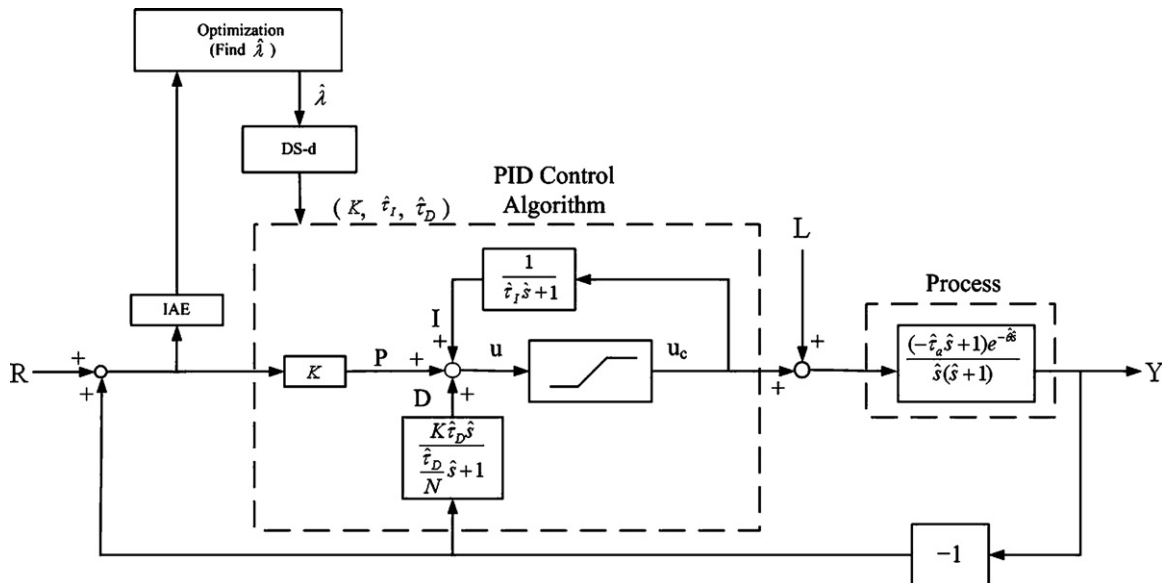

Fig. 4. Block diagram of the dimensionless system with optimum searching.

where $\hat{\tau}_a = \tau_a/\tau$ and $\hat{\theta} = \theta/\tau$ are all dimensionless variables. Similarly, the parameters of PID control algorithm can also be represented as dimensionless forms, i.e. $\hat{\tau}_I = \tau_I/\tau$ and $\hat{\tau}_D = \tau_D/\tau$. In addition, the dimensionless closed-loop time constant is denoted as $\hat{\lambda} = \lambda/\tau$, and the DS-d PID tuning relationships of Eqs. (7)–(9) then become

$$K = K_c K_p \tau = \frac{(1 + \hat{\theta} + \hat{\tau}_a)(3\hat{\lambda} + \hat{\theta} + \hat{\tau}_a)}{(\hat{\lambda} + \hat{\theta} + \hat{\tau}_a)^3} \quad (16)$$

$$\hat{\tau}_I = 3\hat{\lambda} + \hat{\theta} + \hat{\tau}_a \quad (17)$$

$$\hat{\tau}_D = \frac{3(\hat{\theta} + \hat{\tau}_a)\hat{\lambda} + (\hat{\theta} + \hat{\tau}_a)^2 - \hat{\lambda}^3 + 3\hat{\lambda}^2}{(3\hat{\lambda} + \hat{\theta} + \hat{\tau}_a)(\hat{\theta} + \hat{\tau}_a + 1)} \quad (18)$$

Subsequently, a dimension feedback control system based on the process model for computer searing is given in Fig. 4. For a given process model, i.e. $\hat{\tau}_a$ and $\hat{\theta}$, the response of dimensionless control system in Fig. 4 to a step change in the load disturbance (L) can therefore be obtained by a simulation using Matlab and Simulink. Without losing linearity, a small magnitude (say 0.2) of step change in load disturbance has been chosen, and the IAE value for the step change can therefore be obtained, as shown in Fig. 4. The definition of IAE (integral of the absolute value of the error) is

$$IAE = \int_0^{\hat{t}_f} |e(\hat{t})| d\hat{t} \quad (19)$$

where \hat{t}_f is the dimensionless final time. In this study, \hat{t}_f is chosen to be the time at which $|e(\hat{t})|$ is continuously less than 10^{-10} for 1000 dimensionless sampling times. This ensures that the step-response approaches steady state at this time. Furthermore, a typical plot of IAE versus $\hat{\lambda}$ for $\hat{\tau}_a = 0.5$ under various $\hat{\theta}$ using PID control is drawn in Fig. 5. It can be found from Fig. 5 that IAE has a minimum value; the relationship between IAE versus $\hat{\lambda}$ for given model parameters (i.e., $\hat{\tau}_a$ and $\hat{\theta}$) is a unimodal function [13]. Thus, optimization of the system response based on the minimum IAE criterion involving the determination of the parameter $\hat{\lambda}$ is implemented by the golden-section search method [13], as shown in Fig. 4. Then, PID parameters of the dimensionless system, i.e., K , $\hat{\tau}_I$, and $\hat{\tau}_D$, are calculated by the dimensionless DS-d block in Fig. 4 using Eqs. (16)–(18). The optimum $\hat{\lambda}$, instead of optimum PID parameters, for minimum IAE, therefore, can be obtained from the given model parameters by computer searching.

As shown in Fig. 4, optimum $\hat{\lambda}$ (or λ/τ) data based on the process model for several discrete values of $\hat{\tau}_a$ and $\hat{\theta}$ can be obtained by computer searching. The specified ranges of $0.01 \leq \tau_a/\tau \leq 1.0$ and $0.01 \leq \theta/\tau \leq 1.0$, which are considered to be the most applicable

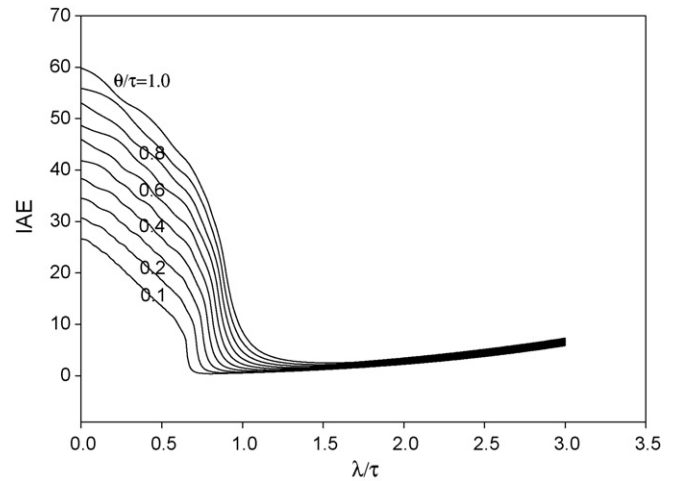

Fig. 5. A typical plot of IAE versus λ/τ for $\tau_a/\tau = 0.5$ under PID control.

ranges for the model, are searched in this study. Fig. 6(a) shows optimum values of λ/τ , which are obtained by computer searching, with respect to various model parameters τ_a/τ and θ/τ . Numerical values of these optimum data lie within the range of $0.05 < \lambda/\tau < 1.90$. These data are then empirically fitted into an equation by a least-squares method. The criterion of standard error of estimate (SE) is employed for selecting an empirical equation. Examination of SE indicates that the smaller the value of SE, the more precise the predictions. Besides, the multiple correlation coefficient (R), which corresponds to an F -test on least-squares fitting, is also employed, and R closing to 1.0 means a good fit. [14] The fitting result for these optimum λ/τ data therefore is:

$$\frac{\lambda}{\tau} = 0.1569 + 1.3228 \left(\frac{\theta}{\tau}\right) + 1.1616 \left(\frac{\tau_a}{\tau}\right) - 0.4092 \left(\frac{\theta}{\tau}\right)^2 - 0.3544 \left(\frac{\tau_a}{\tau}\right)^2 \quad (R = 0.9995, \text{ SE} = 0.0332) \quad (20)$$

Accordingly, the appropriate tuning factor λ can be directly calculated from the process parameters (τ_a , τ , and θ) via Eq. (20) in ranges of $0.01 \leq \tau_a/\tau \leq 1.0$ and $0.01 \leq \theta/\tau \leq 1.0$. Then, one can obtain the tuning parameters of PID controller by substituting the calculated λ and the model parameters into Eqs. (7)–(9). Furthermore, a comparison between these λ/τ data obtained by computer searching and those λ/τ values calculated by Eq. (20) is also given in Fig. 6(b). It can be found from the scatter plot of Fig. 6(b) that the fitting

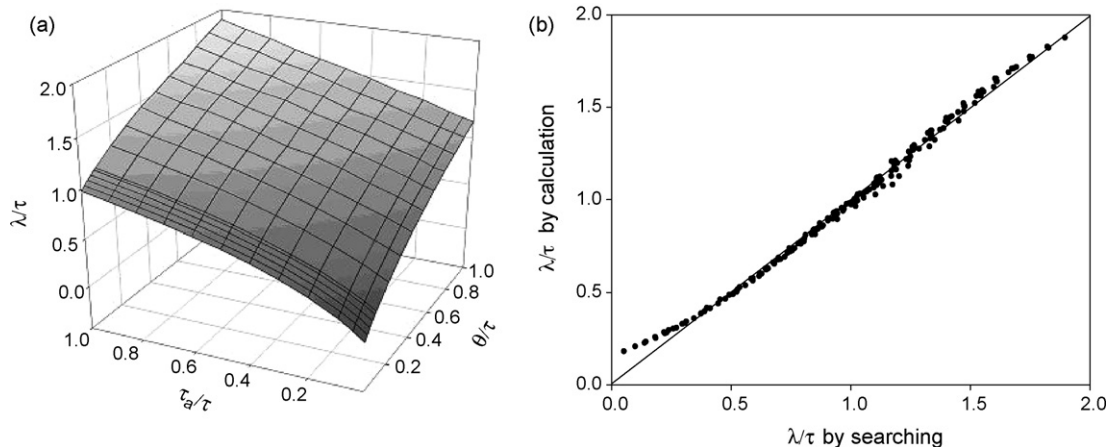

Fig. 6. Optimum search results for PID control. (a) Optimum values of λ/τ . (b) Scatter plot for curve fitting results.

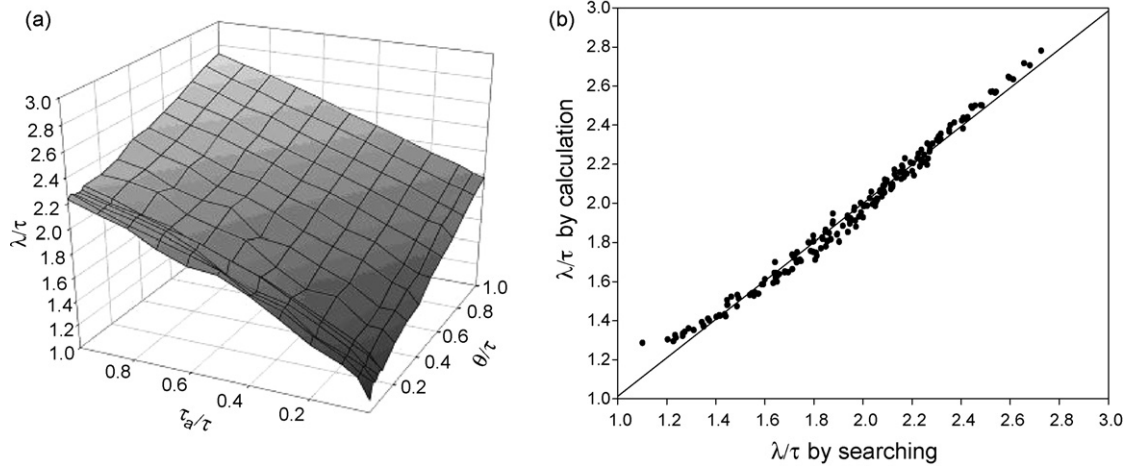

Fig. 7. Optimum search results for PI control. (a) Optimum values of λ/τ . (b) Scatter plot for curve fitting results.

results are generally close to the original data, except for the lower values of λ/τ .

3.2. Tuning for PI controller

For an industrial boiler drum, using a PI level controller is more popular than using a PID level controller. Luyben [3] has pointed out that the derivative action is seldom used in these applications because of the noisy level signal. However, to develop analytical expressions for PI controller tuning either from Eq. (1) or from Eq. (5) using the DS-d method of Chen and Seborg [4] can normally not succeed. In order to solve this problem, we simply let $\hat{\tau}_D = 0$ in Fig. 4 to find an optimum $\hat{\lambda}$ while retaining the benefits of the DS-d control system. Thus, there are only Eqs. (16) and (17) in the DS-d block of Fig. 4 for computer calculations. These optimum values of λ/τ obtained by computer searching for DS-d PI control in the range of $0.01 \leq \tau_a/\tau \leq 1.0$ and $0.01 \leq \theta/\tau \leq 1.0$, therefore, are given in Fig. 7(a). Numerical values of these optimum data lie within the range of $1.10 < \lambda/\tau < 2.73$. Again, these data are then empirically fitted into an equation by a least-squares method, and the fitting result is

$$\frac{\lambda}{\tau} = 1.2700 + 0.4271 \left(\frac{\theta}{\tau} \right) + 1.2173 \left(\frac{\tau_a}{\tau} \right) + 0.1699 \left(\frac{\theta}{\tau} \right)^2 - 0.3032 \left(\frac{\tau_a}{\tau} \right)^2 \quad (R = 0.9998, \text{ SE} = 0.0424) \quad (21)$$

Accordingly, the appropriate tuning factor λ for PI control can be directly calculated from the process parameters (τ_a , τ , and θ) via Eq. (21) in ranges of $0.01 \leq \tau_a/\tau \leq 1.0$ and $0.01 \leq \theta/\tau \leq 1.0$. Then, upon substituting the calculated λ into Eqs. (7) and (8), one can obtain the tuning parameters for PI controller. Furthermore, a comparison between these λ/τ data obtained by computer searching and those λ/τ calculated by Eq. (21) for PI controller settings is also given in Fig. 7(b). It can be found from the scatter plot of Fig. 7(b) that the fitting results are generally close to the original data, except for the lower values of λ/τ . A nonlinear least-squares fitting can normally not be perfect, especially in such multi-variable problems. It has also been found that the calculated λ/τ using these formulas may not be so optimum on Figs. 6 and 7 in the condition when both values of τ_a/τ and θ/τ are quite small (say, approaching to 0.01). Thus, the tuning formulas of Eqs. (20) and (21) can only provide appropriate λ values, which are closing to optimum. In addition, it should be noted that these formulas of Eqs. (20) and (21) are empirical and should not be extrapolated beyond the correlation ranges, i.e. $0.01 \leq \tau_a/\tau \leq 1.0$ and $0.01 \leq \theta/\tau \leq 1.0$.

3.3. Set-point weighting

DS-d design methods are usually based on specification of the desired closed-loop transfer function for load/disturbance changes. Consequently, the resulting DS-d controllers tend to perform well for load/disturbance responses, but the set-point change might not be satisfactory. Chen and Seborg [4] employed a set-point weighting, which was originally proposed by Åström and Hägglund [9], to reduce large overshoot for DS-d controllers. A set-point weighting for PI control structure is:

$$u(t) = K_c \left\{ [br(t) - y(t)] + \frac{1}{\tau_I} \int_0^t [r(\tau) - y(\tau)] d\tau \right\} \quad (22)$$

where b is the set-point weighting coefficient, and $0 \leq b \leq 1$. Furthermore, Chen and Seborg [4] also pointed out that the large overshoot for the set-point response of the DS-d PI/PID controller can normally be eliminated by setting $b=0.5$. Accordingly, the set-point weighting with $b=0.5$ is also employed for the proposed DS-d PI/PID settings throughout the servo-control studies.

4. Simulation examples

In order to evaluate the effectiveness of the proposed controller tuning method, a simulation study is performed using three numerical examples. Throughout the simulation, the reset-feedback PID control algorithm as shown in Fig. 3 is employed, and the controller output may meet constraints. Without losing linearity, a step change with small magnitude 0.2 is introduced either in disturbance or in set point for the simulation studies of Examples 1 and 2. Example 3 presents a simulation study in which the process is upset by a large load change with magnitude of 0.8. Performance of the closed-loop response for each case is evaluated by IAE, settling time (t_s), percent overshoot (OS%), and maximum peak height (M_p). For both disturbance and set-point changes, the settling time (t_s) here is defined as the error to come within some prescribed band of the steady-state value (i.e., zero) and remain in this band. The band limits ± 0.005 are chosen in this study. In addition, the overshoot is the maximum peak deviation exceeding the ultimate value of response curve to the magnitude of set-point change. The maximum peak height (M_p), which is also called the maximum deviation [12], is used for load/disturbance change. Furthermore, the set-point weighting coefficient $b=0.5$ is also chosen for servo-control studies.

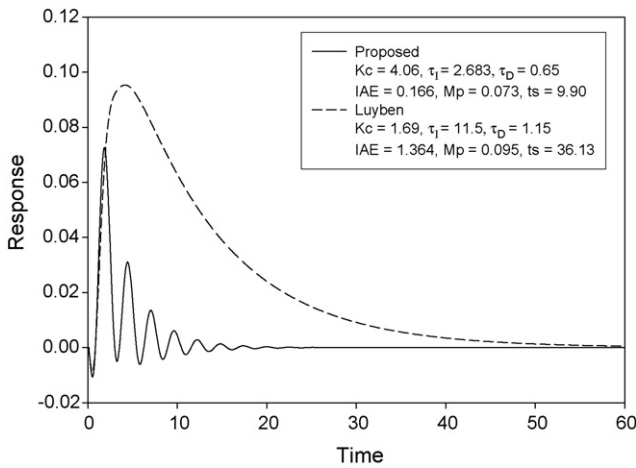

Fig. 8. Comparison of disturbance responses using PID control for Example 1.

Example 1. The case studied by Luyben [3] is considered, where the process is described by

$$G_p(s) = \frac{0.547(-0.418s + 1)e^{-0.1s}}{s(1.06s + 1)} \quad (23)$$

Substituting the above process parameters into Eq. (20), the tuning factor $\lambda = 0.722$ is calculated. Then, substituting the λ value and the process parameters into Eqs. (7)–(9), one has $K_c = 4.066$, $\tau_I = 2.683$, and $\tau_D = 0.650$ for PID controller tuning. Typical response curves based on the proposed settings and that of Luyben [3] to a disturbance change with magnitude 0.2 are shown in Fig. 8. It is clear that the proposed settings can get faster response than that of Luyben. In addition, comparing the IAE values in Fig. 8, the proposed tuning has IAE=0.166, and Luyben’s tuning has IAE=1.364. From these results, it is evident that the proposed method can provide better controller tuning than that of Luyben [3].

Furthermore, closed-loop response curves of the proposed PID settings and that of Luyben [3] for a set-point change with magnitude of 0.2 are shown in Fig. 9. It is found in Fig. 9 that Luyben’s tuning is very good for set-point changes, especially for lower overshoot and less oscillation. Without the set-point weighting coefficient, i.e. $b = 1$ in Eq. (22), the proposed settings, however, can not perform well, since the overshoot is large. One reason to explain is that Luyben’s tuning is based on the servo control and the proposed tuning is based on the regulatory control. Fortunately,

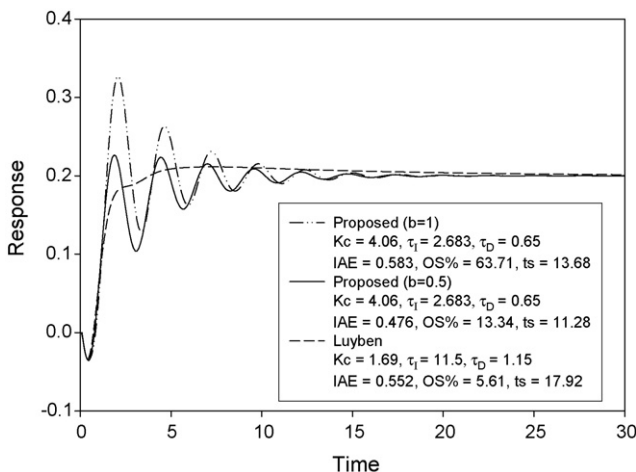

Fig. 9. Comparison of set-point responses using PID control for Example 1.

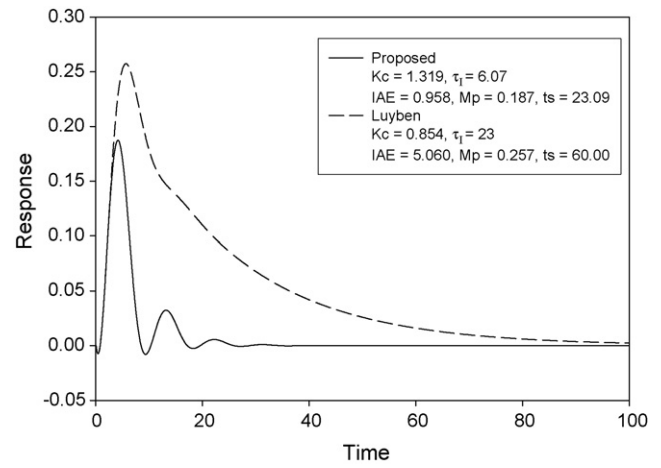

Fig. 10. Comparison of disturbance responses using PI control for Example 1.

the embedded set-point weighting coefficient with $b = 0.5$ of the proposed DS-d PID tuning can really give a dramatic reduction in overshoot. As shown in Fig. 9, the IAE value for $b = 0.5$ is also good; however, the response is still oscillatory, owing to the characteristics of the process dynamics, i.e. Eq. (1), the settling time (t_s) for each case in Fig. 9 is considered to be long. Compared to the Luyben’s tuning, the t_s value for each DS-d tuning case seems to be less.

Similarly, one can obtain a tuning factor $\lambda = 1.849$ for PI controller settings by substituting the process parameters into Eq. (21). Then, $K_c = 1.319$ and $\tau_I = 6.065$ are obtained by substituting the λ value and the process parameters into Eqs. (7) and (8). The step-response curves with their IAE values for the proposed PI settings and that of Luyben [3] are shown in Fig. 10. From Fig. 10, it is clear that the proposed tuning can get better performance than Luyben’s tuning for load/disturbance changes. Moreover, the closed-loop responses for the above PI controller settings for a set-point change with magnitude of 0.2 in this process are shown in Fig. 11. It is found from Fig. 11 that the performance of Luyben’s tuning is fine. The proposed tuning embedded the set-point weighting coefficient $b = 0.5$, however, can really improve the performance of the corresponding response, although the overshoot and oscillatory still exist.

Example 2. Industrial processes often possess very high order dynamics. In order to evaluate the effectiveness of the proposed

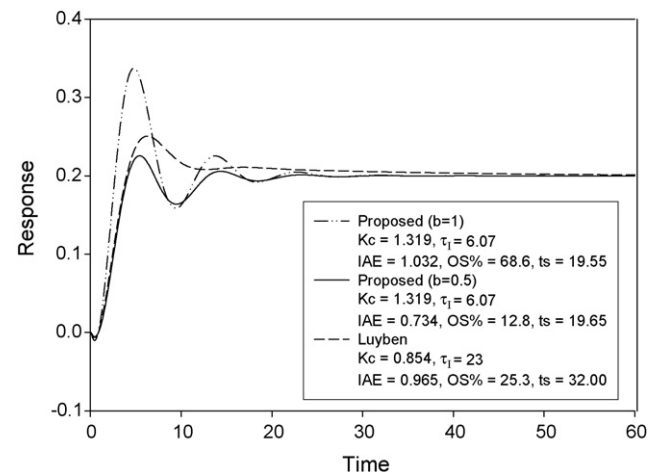

Fig. 11. Comparison of set-point responses using PI control for Example 1.

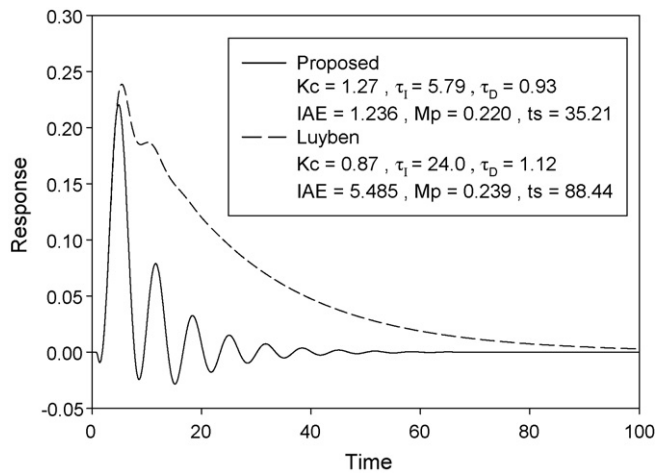

Fig. 12. Comparison of disturbance responses using PID control for Example 2.

method for higher-order processes, a fourth-order integrating process with deadtime and inverse response:

$$G_p(s) = \frac{0.5(-0.5s + 1)e^{-0.7s}}{s(0.4s + 1)(0.1s + 1)(0.5s + 1)} \quad (24)$$

is assumed to be the actual process dynamics. Using step-response data of Eq. (24) and a nonlinear least-square fit, the actual process then is approximated to the process model, \tilde{G}_p , as

$$\tilde{G}_p(s) = \frac{0.5183(-0.4699s + 1)e^{-0.81s}}{s(1.1609s + 1)} \quad (25)$$

A comparison of the actual process response and the model response is also given in Fig. 1.

Then, a tuning factor $\lambda = 1.501$ is obtained by substituting the model parameters of Eq. (25) into Eq. (20). Subsequently, the PID controller settings based on the nominal process model, i.e. Eq. (25), are sought by substituting the λ value and model parameters into Eqs. (7)–(9). The proposed PID settings based on the nominal model of Eq. (25), therefore, are: $K_c = 1.267$, $\tau_i = 5.782$, and $\tau_D = 0.925$. In addition, PID controller tuning based on the nominal process model using Luyben's method [3] is also obtained, and the tuning parameters are: $K_c = 0.867$, $\tau_i = 24$, and $\tau_D = 1.12$. Furthermore, the step responses of the actual process, i.e. Eq. (24), using the above PID controller settings under various changes are shown in Figs. 12 and 13.

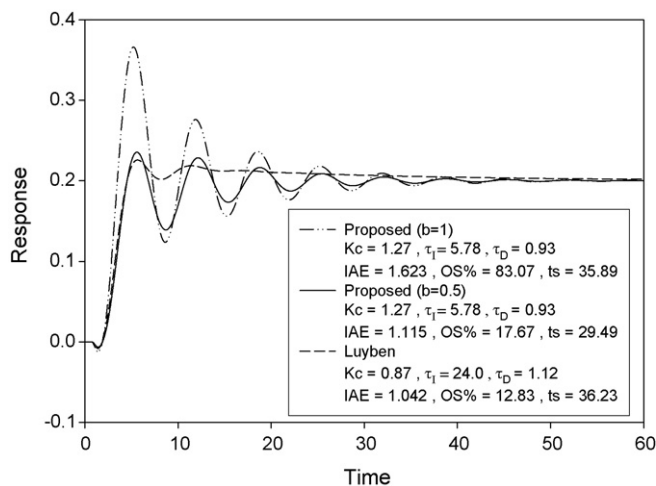

Fig. 13. Comparison of set-point responses using PID control for Example 2.

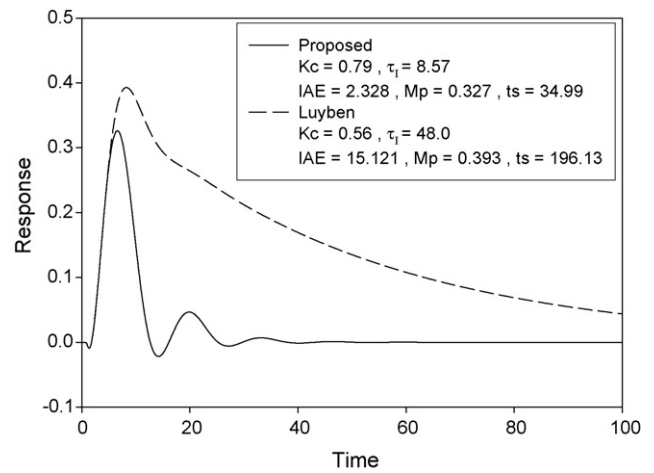

Fig. 14. Comparison of disturbance responses using PI control for Example 2.

Moreover, the proposed PI controller settings are sought by the similar procedures, and the results are: $K_c = 0.790$ and $\tau_i = 8.572$. Still, one finds $\lambda = 2.431$ by substituting the model parameters of Eq. (25) into Eq. (21), and then substitutes this λ and the model parameters into Eqs. (7) and (8). In addition, PI controller settings based on Eq. (25) using Luyben's method are also obtained, and the tuning parameters are: $K_c = 0.563$ and $\tau_i = 48$. The step responses of the actual process, i.e. Eq. (24), using the above PI controller settings under various changes are shown in Figs. 14 and 15. The simulation results for this example are just similar to that of Example 1. Luyben's tuning [3] can get a lower overshoot and less oscillation for set-point changes. The proposed settings, however, can get lower IAE value and faster response than Luyben's tuning for load/disturbance changes.

Example 3. Industrial processes may sometime encounter an unusually large amount of load disturbance, and the final control element (or control valve) may reach a limit. When the valve cannot be adjusted, the error remains nonzero for long periods of time, and the ideal PID control algorithm, e.g. Eq. (4), continues to calculate values of the controller output. The integral mode continually integrates the error, and the controller output value, therefore, becomes a very large magnitude. Since the final control element can change only within a restricted range, the large controller output cannot affect the process. This situation is known as reset (integral) windup, and it can cause a very poor control performance [10]. The

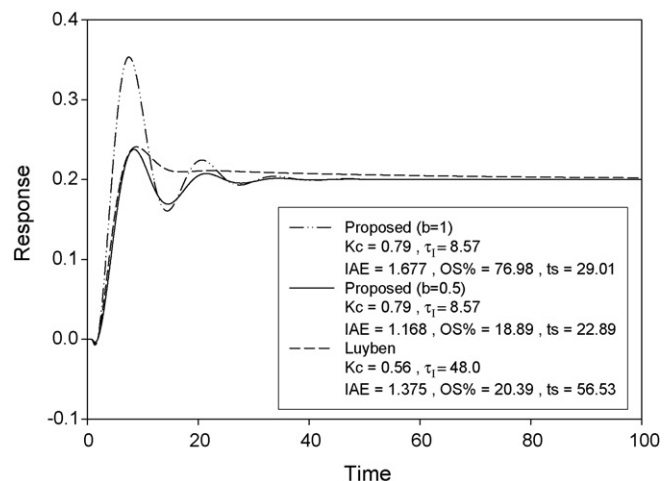

Fig. 15. Comparison of set-point responses using PI control for Example 2.

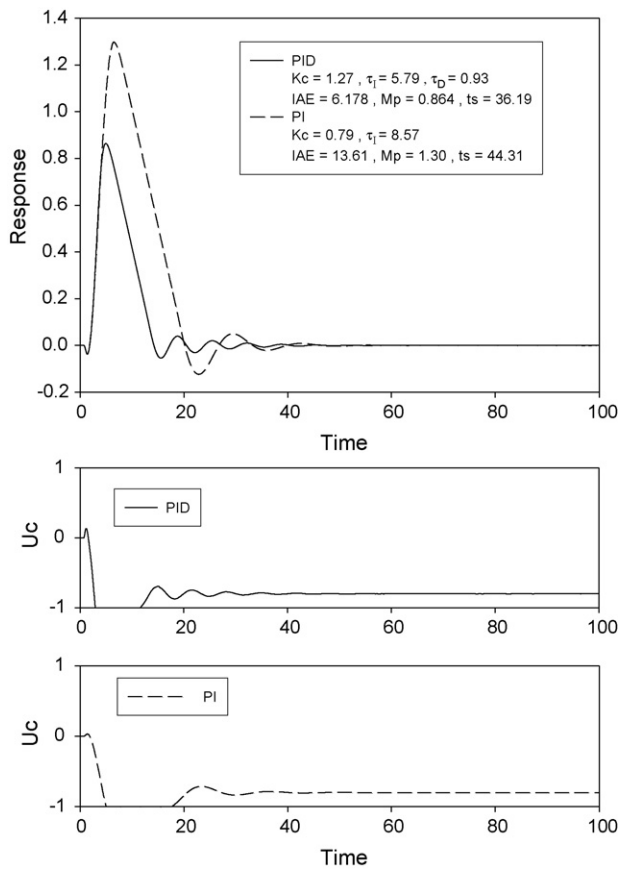

Fig. 16. Step responses to a large load change for Example 3.

reset-feedback PID algorithm adopted in this study in Fig. 3 is considered to be an anti-reset-windup algorithm. In order to evaluate the effectiveness of the proposed techniques for anti-reset windup, the same process and same tuning parameters of Example 2 are chosen in this study. Different from Example 2, a large step change with magnitude of 0.8 is introduced in the load disturbance. The simulation results in Fig. 16 show that the controller output (u_c) for either PID or PI control has met the constraint. Nevertheless, the control performances of the proposed techniques seem to be still fine.

5. Conclusions

Industrial processes will sometimes encounter the dynamics having integrator with deadtime and inverse response, say boiler level control. Such processes are considered to be difficult to control in process industries. Nevertheless, publications discussed on such process control still seem to be relatively scarce in the literature. Luyben [3] developed a servo tuning technique, which needs iteratively find PI/PID parameters in frequency-domain using Matlab software. However, the regulatory control is normally much more important than the servo control for such processes. A computer-based study of a transfer-function model using DS-d equations for practical PI/PID controller settings in the most applicable ranges,

therefore, is conducted in this investigation. Subsequently, PI/PID controller tuning based on the model parameters for regulatory control can be expediently obtained by simple calculations. The main advantage of the proposed technique is that proper PI/PID controller settings could be promptly sought by using a pocket calculator without any tedious design or on-line trial-and-error.

Furthermore, the DS-d expressions for PI/PID tuning employed in this study, i.e. Eqs. (7)–(9), are only approximated equations, but the optimum λ data are obtained under a very strict environment of computer searching using the reset-feedback PID algorithm. Thus, practical applications of these equations to the process are still quite effective. In addition, DS-d design methods are usually based on specification of the desired closed-loop transfer function for load/disturbance changes. Consequently, the resulting DS-d controllers tend to perform well for regulatory control, but the servo control might not be satisfactory. From the simulation results in Examples 1 and 2, it is found that Luyben's tuning, which is developed based on the servo control, is very good for set-point changes, especially for lower overshoot and less oscillation. Due to the chosen IAE criterion, responses of the proposal tuning are oscillation in most cases. In addition, without the set-point weighting coefficient, the proposed DS-d settings normally do not perform well for servo control. Fortunately, the proposed DS-d PI/PID settings with weighting coefficient $b = 0.5$ can really improve the performance for set-point changes. On the other hand, the proposed DS-d PI/PID settings, however, can get much better performance than Luyben's settings for regulatory control. Comparing IAE values for disturbance changes in these simulation examples, it is evident that the proposed settings can provide dramatically lower IAE values than that of Luyben [3]. Moreover, industrial processes may sometime encounter an unusually large amount of load disturbance. Simulation results in Example 3 have demonstrated that using the reset-feedback PID algorithm and the proposed tuning formulas can still perform well for large load change.

References

- [1] K.J. Åström, R.D. Bell, Drum-boiler dynamics, *Automatica* 36 (2000) 363–378.
- [2] H. Kim, S. Choi, A model of water level dynamics in natural circulation drum-type boilers, *Int. Commun. Heat Mass Transfer* 32 (2005) 786–796.
- [3] W.L. Luyben, Identification and tuning of integrating processes with deadtime and inverse response, *Ind. Eng. Chem. Res.* 42 (2003) 3030–3035.
- [4] D. Chen, D.E. Seborg, PI/PID controller design based on direct synthesis and disturbance rejection, *Ind. Eng. Chem. Res.* 41 (2002) 4807–4822.
- [5] E.B. Dahlin, Designing and tuning digital controllers, *Instrum. Control Syst.* 41 (6) (1968) 77–83.
- [6] C.L. Smith, *Digital Computer Process Control*, Intext Educational Publishers, 1972.
- [7] C.-T. Huang, Y.-S. Lin, Tuning PID controller for open-loop unstable processes with time delay, *Chem. Eng. Commun.* 133 (1995) 11–30.
- [8] C.-T. Huang, C.-J. Chou, J.-L. Wang, Tuning of PID controllers based on the second-order model by calculation, *J. Chin. Inst. Chem. Eng.* 27 (1996) 107–120.
- [9] K.J. Åström, T. Hägglund, *PID Controllers: Theory, Design, and Tuning*, 2nd ed., Instrument Society of America, Research Triangle Park, NC, 1995.
- [10] C.A. Smith, A.B. Corripio, *Principles and Practice of Automatic Process Control*, 3rd ed., John Wiley & Sons, Inc., 2006.
- [11] F.G. Shinskey, *Feedback Controllers for the Process Industries*, McGraw-Hill, Inc., 1994.
- [12] T.E. Marlin, *Process Control: Designing Processes and Control Systems for Dynamic Performance*, 2nd ed., McGraw-Hill, Inc., 2000.
- [13] T.F. Edgar, D.H. Himmelblau, *Optimization of Chemical Processes*, 2nd ed., McGraw-Hill, Inc., 2001.
- [14] N.R. Draper, H. Smith, *Applied Regression Analysis*, 2nd ed., John Wiley & Sons, Inc., 1981.