



Intelligent multi-sensor control system based on innovative technology integration via ZigBee and Wi-Fi networks

Kuang-Yow Lian^a, Sung-Jung Hsiao^a, Wen-Tsai Sung^{b,*}

^a Department of Electrical Engineering, National Taipei University of Technology, Taiwan

^b Department of Electrical Engineering, National Chin-Yi University of Technology, Taiwan

ARTICLE INFO

Article history:

Received 16 June 2012

Received in revised form

25 September 2012

Accepted 12 December 2012

Available online 5 January 2013

Keywords:

ZigBee

Wi-Fi

Ethernet

XBee

Android

ABSTRACT

Data transmission network integration is one of the most difficult problems to solve in wireless sensor network systems. ZigBee and Wi-Fi belong to different network protocols. If a network system must use both ZigBee and Wi-Fi at the same time to transmit data a considerable challenge is presented. This paper introduces a novel hardware method that integrates ZigBee and Wi-Fi. The proposed method is based on the Arduino wearable module ZigBee and Ethernet concept. This study builds an intelligent home appliance control system using the ZigBee network. This intelligent control system uses an integrated ZigBee and Wi-Fi network architecture in the house. Our study sends the ZigBee sensor messages to a cloud database through the TCP/IP protocol network containing the physical network and wireless network device lines. Control management access is achieved using smart phones. The proposed method is very simple and easy to implement using Arduino circuits. The effectiveness of the proposed method is verified by the simulation and experimental results. The hardware components include the Arduino controller, XBee Series 2 wireless communication module and end device sensors. The Android and Java programming languages are used to write the smart phone and Server recognition programs.

© 2012 Elsevier Ltd. All rights reserved.

1. Introduction

The recent rapid development of network technology has given people comfort and convenience. People all over the world can obtain much information and efficient control of electrical devices using the home sensor network (Lien et al., 2007; Erdem and Üner, 2009). The most important part of every home security system is the secure identification module (Yuksekkaya et al., 2006; Chia-Hung et al., 2007). There are many ways to manage secure identification entry; password, RFID sensors, fingerprint scan and face recognition (Scott Vernon and Joshi, 2011). There are also shortcomings in security system implementation, such as the keyboard lock being too small, mobility problems with the elderly or disabled, inconvenient keyboard for inputting username and password and RFID induction easily stolen or lost. Some people find fingerprint and face recognition methods objectionable because the privacy of the body is used as a recognition tool. Some people do not want their own fingerprints and face images established in any database (Teng et al., 2010).

This paper proposes a method that uses mobile phones to hand-write words or symbols for identity. This is an excellent,

innovative way that improves identity security. At present cell phones are ubiquitous in civilized society, used by all for phone, sending text messages, Internet and Facebook (Chen et al., 2009). Phones are carried at all times by all (Teixeira et al., 2010; Khmelevsky and Voytenko, 2010).

The system architecture diagram for the proposed access control system is shown in Fig. 1.

Smart phones can be used to monitor and control the status of the ZigBee network as shown in Fig. 2.

According to the ZigBee Alliance literature, ZigBee network noise is the least compared with other wireless networks. Please refer to Fig. 3.

2. Hardware analysis

The XBee Series 2 from the Digi Company is employed as the ZigBee nodes. The Series 2 uses a microchip from Ember Networks that enables standard-based ZigBee mesh networking. Mesh networking is the center for creating robust sensor networks, systems that can generate an immense wealth of data or support intricate human-scale interactions. Fig. 4 shows the XBee device in regular and PRO type.

The X-CTU default settings will usually work for brand-new XBee devices configured at the factory. The easiest way to confirm

* Corresponding author. Tel.: +886 4 23924505x2170; fax: +886 4 23924419.
E-mail address: songchen@ncut.edu.tw (W.-T. Sung).

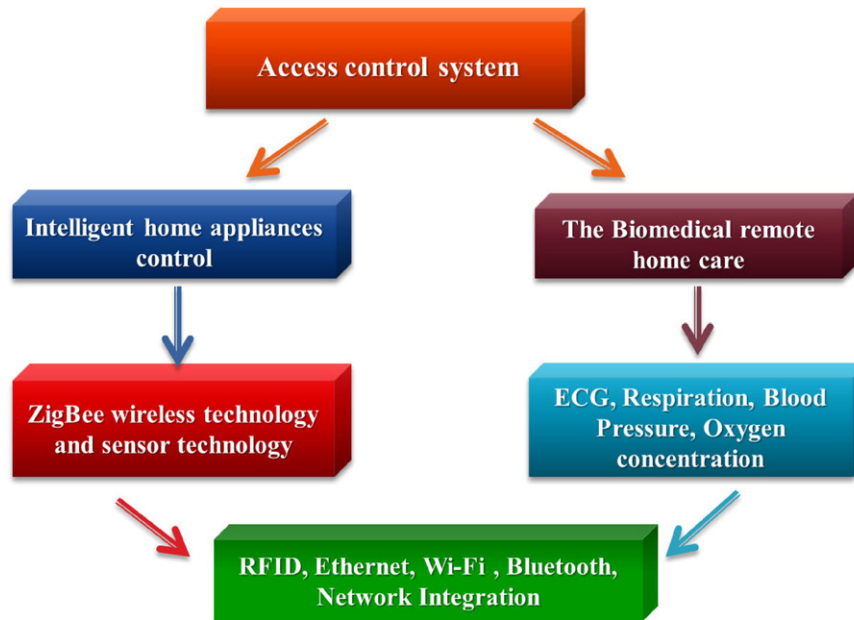

Fig. 1. Intelligent control system framework.

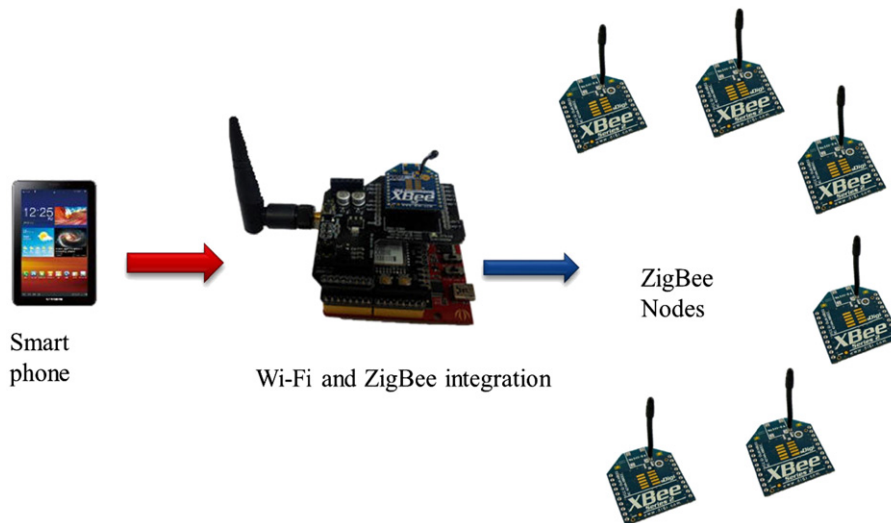

Fig. 2. Wi-Fi and ZigBee integration.

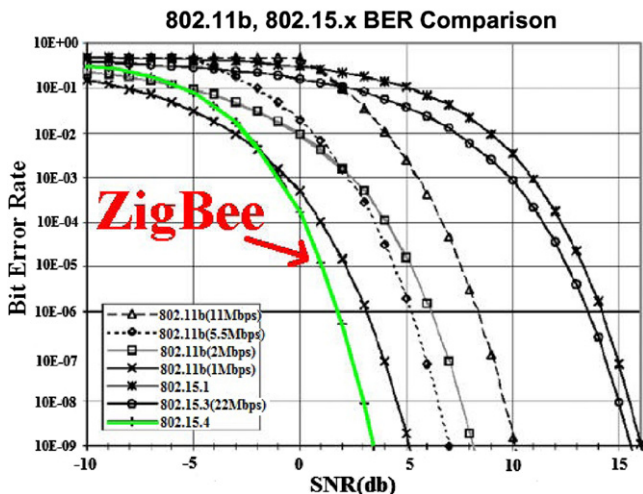

Fig. 3. 802.15.4 has excellent performance in low SNR environments.

that everything is set up correctly is to click on the Test/Query button once the user has selected a COM port. Please refer to the screen in Fig. 5.

ZigBee and Wi-Fi module integration through the Arduino controller simultaneously operates two different network protocols and data transfer actions. A Wi-Fi and ZigBee module is integrated on the Arduino motherboard in Fig. 6.

Researchers can also use the Ethernet and ZigBee integration module. Fig. 7 shows the Ethernet and ZigBee module integrated in the top of the Arduino controller (Graves et al., 2009).

3. Problems and overcoming

This research uses the Arduino controller to connect to a ZigBee device or Wi-Fi module while receiving (RX) and transmitting. (TX) TTL controller serial data pins will also be used. Fig. 8 shows a typical Arduino controller and ZigBee node connection diagram. The ZigBee device is occupied by one TX and one RX pin.



Fig. 4. XBee device in regular and PRO type.

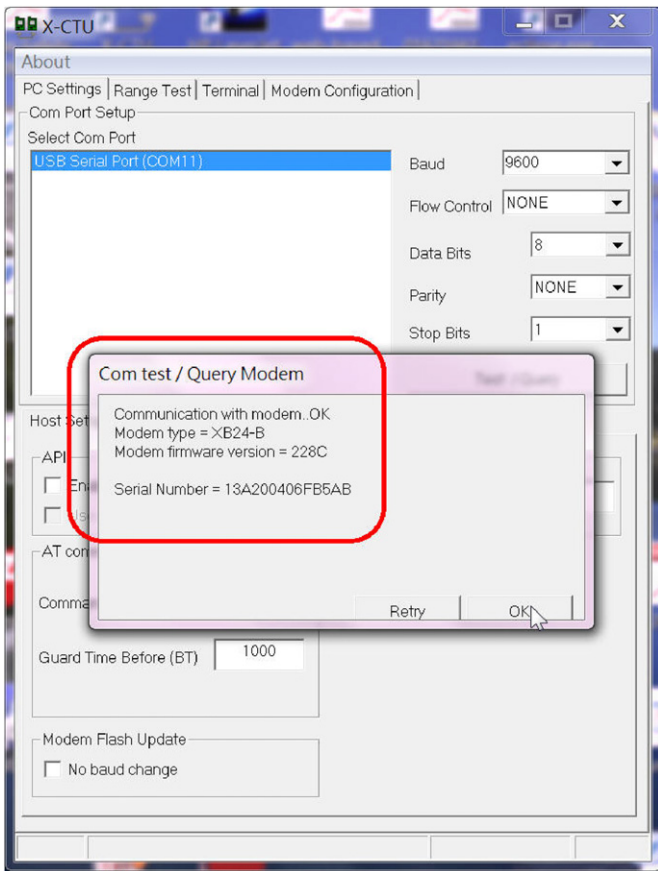

Fig. 5. X-CTU starting screen.

Suppose that in Fig. 8 this Arduino is also connected to another Wi-Fi module. This will not be completed because the Arduino has no TX and RX pins for use. Therefore, we use the Arduino Mega 2560 controller to solve this problem. Fig. 9 is an overview diagram of the Mega 2560 module. The upper right corner of the diagram shows the communication connection area. There are four pairs of TX and RX pins on the Arduino Mega controller.

Serial: 0 (RX) and 1 (TX); Serial 1: 19 (RX) and 18 (TX); Serial 2: 17 (RX) and 16 (TX); Serial 3: 15 (RX) and 14 (TX). Used to

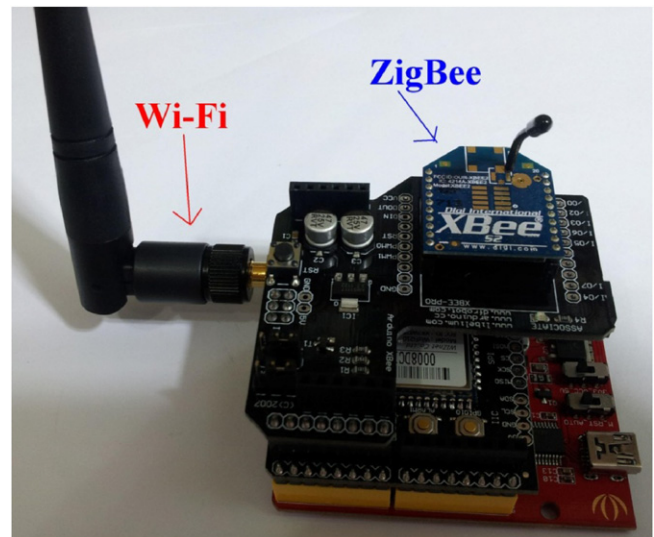

Fig. 6. Wi-Fi and ZigBee module is integrated on the motherboard of the Arduino.

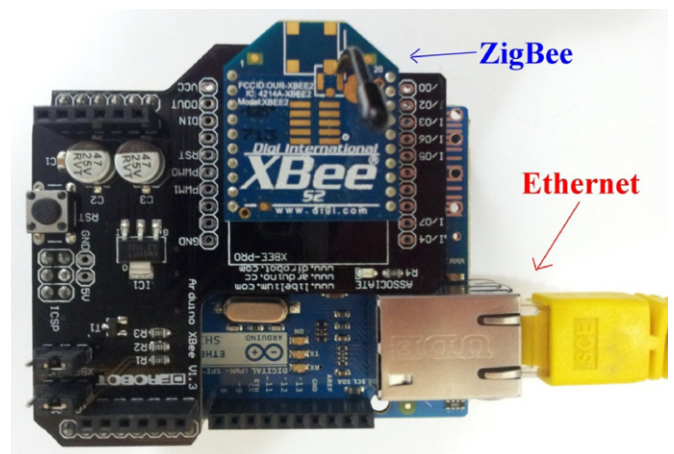

Fig. 7. Ethernet and ZigBee modules integrated on top of the Arduino controller.

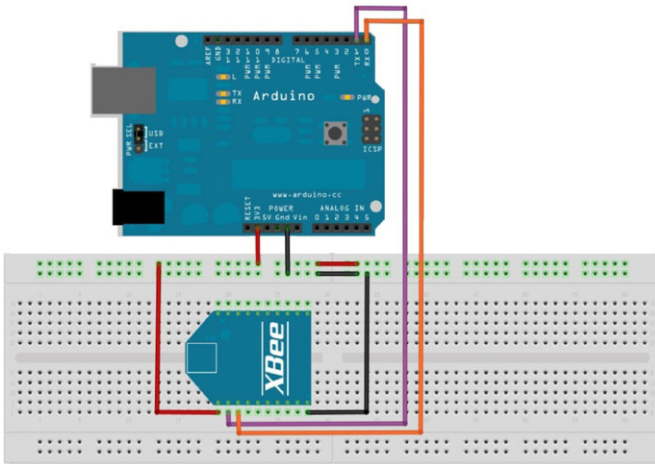

Fig. 8. Arduino and ZigBee node hack breadboard layout.

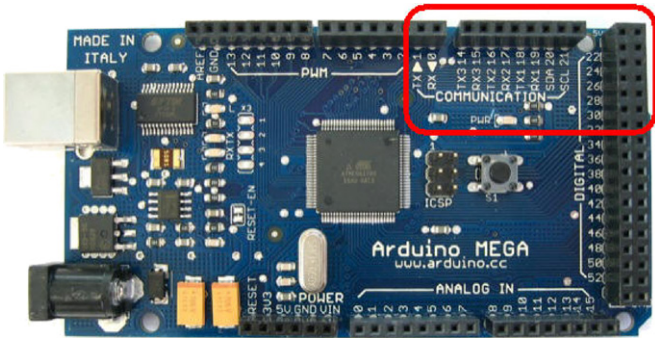

Fig. 9. Arduino Mega 2560 modules.

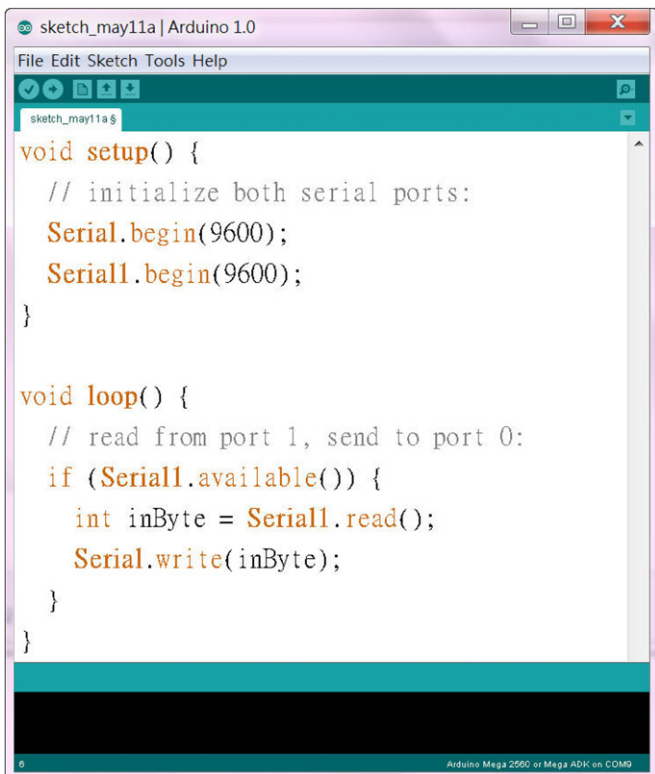

Fig. 10. Different the ports of the Serial code examples.

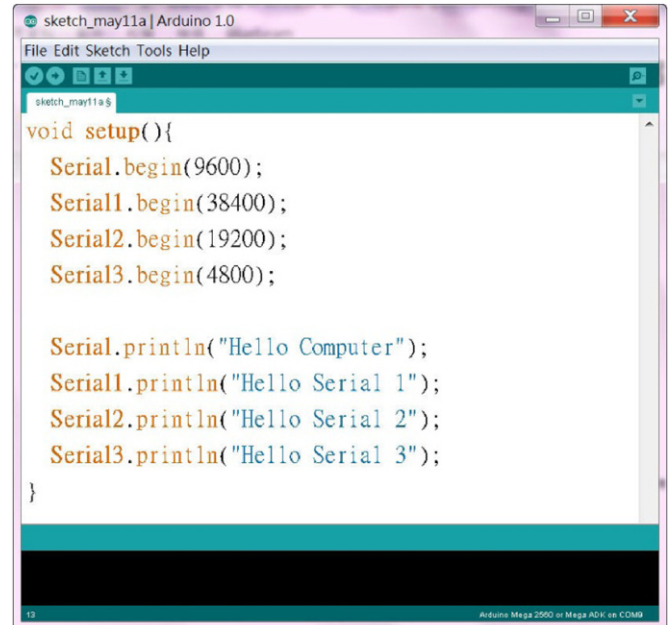

Fig. 11. Four serial transmission port code samples.

receive (RX) and transmit (TX) TTL serial data. Pins 0 and 1 are also connected to the corresponding FTDI USB-to-TTL Serial chip pins. External Interrupts: 2 (interrupt 0), 3 (interrupt 1), 18 (interrupt 5), 19 (interrupt 4), 20 (interrupt 3), and 21 (interrupt 2). These pins can be configured to trigger an interrupt at a low value, a rising or falling edge, or a change in value. PWM: 2–13 and 44–46. Provide 8-bit PWM output with the analogWrite() function. SPI: 50 (MISO), 51 (MOSI), 52 (SCK), 53 (SS). These pins support SPI communication, which although provided by the underlying hardware is not currently included in the Arduino language. The SPI pins are also broken out on the ICSP header, which is physically compatible with the Duemilanove and Diecimila. I2C: 20 (SDA) and 21 (SCL). Support I2C (TWI) communication using the Wire library (documentation on the Wiring website). Note that these pins are not in the same location as the I2C pins on the Duemilanove or Diecimila.

This research employs serial enabled device that includes XBee Radio, Bluetooth module, RFID reader and another Arduino. For example, the Arduino controller receives data from the main serial port and sends data to the others. The second situation is that the controller receives from serial port 1 and sends to the main serial (Serial 0) Fig. 10.

If users want to use all of these send ports, please refer to the example in Fig. 11.

4. ZigBee network deployment and system route planning

This system consists of two parts for home intelligent control and outside access control. This intelligent control system uses a ZigBee and Wi-Fi integrated network architecture in the house (Hribernik et al., 2011). The door entry management uses the real-time handwriting recognition system using a smart phone (Yu-Chen et al., 2010). Home switch control and sensing uses the ZigBee network and integrated Wi-Fi technology for operation using a smart phone. The ZigBee network deployment in this study is displayed in Fig. 12. The route plan is shown in Fig. 13.

When we are outside the house and want to know the temperature and humidity of a room we can use a smart phone to remotely monitor the home situation. At this point we will use



Fig. 12. ZigBee network deployment.

the Wi-Fi wireless network with the integrated ZigBee network. Temperature sensors via a ZigBee network connection through our integrated technology will instantly allow a smart phone to monitor the room temperature. We can also monitor the home conditions while at home in real time. The entire intelligent control system is shown in Fig. 14

5. Recognition system architecture

Initial access control uses pattern recognition to identify the user's identity. Given the pattern vector of the N $\{X^{(1)}, X^{(2)}, \dots, X^{(N)}\}$, which, the m -th pattern is $X^{(m)} = [x_1^{(m)}, x_2^{(m)}, \dots$

$, x_n^{(m)}], x_i^{(m)} \in \{-1, +1\}, i = 1, \dots, n, m = 1, \dots, N$, discrete Hopfield network the i -th neuron to the j -th neuron of the weight values w_{ij} , using the Hebbian learning rule, as follows:

$$w_{ij} = f(x) = \begin{cases} \sum_{m=1}^N x_i^{(m)} x_j^{(m)} & \text{if } i \neq j \\ 0 & \text{if } i = j \end{cases} \quad (1)$$

The threshold of the i -th neuron, this work can set it as

$$\theta_i = \frac{1}{2} \sum_{j=1}^n w_{ij} \quad (2)$$

When the discrete Hopfield network after completion of the study, it will enter the recall period. At this point, this work inputs

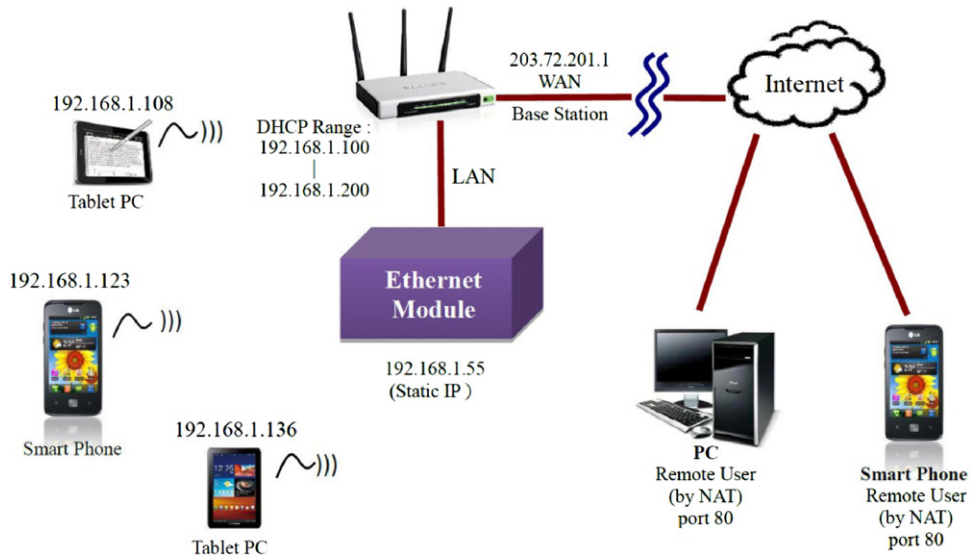

Fig. 13. Route plan system.

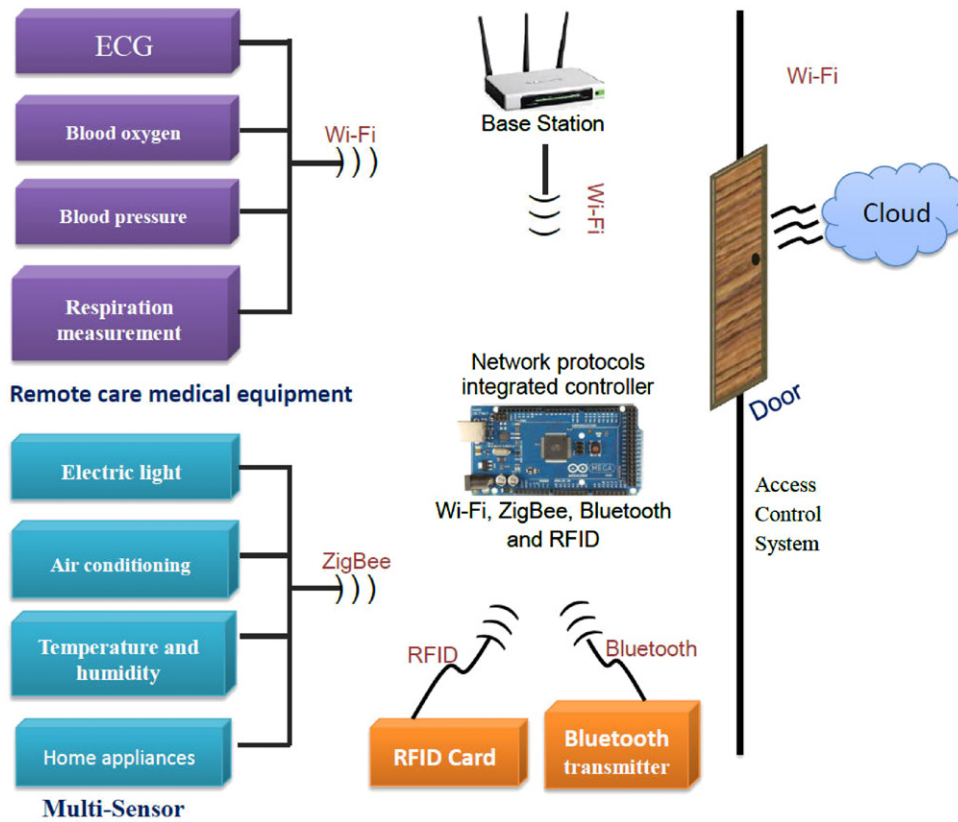

Fig. 14. Intelligent control system architecture.

a pattern vector $X(0) = [x_1(0), \dots, x_n(0)]$, as the initial state of the network. $k+1$ th iteration, the i -th neuron state changes as

$$x_i(k+1) = \text{sgn}(u_i(k+1) - \theta_i) = \begin{cases} 1 & \text{if } u_i(k+1) > \theta_i \\ x_i(k) & \text{if } u_i(k+1) = \theta_i \\ -1 & \text{if } u_i(k+1) < \theta_i \end{cases} \quad (3)$$

which $u_i(k+1) = \sum_{j=1}^n w_{ij}x_j(k), i=1, \dots, n$. In Eq. (3), this study makes use of the energy function concept to prove it within the limited number of iterations to converge to the energy function

local minima, in proving before the first define an energy function

$$\begin{aligned} L(X(k)) &= -\frac{1}{2}X(k)WX^T(k) + X(k)\Theta^T \\ &= -\frac{1}{2}\sum_{i=1}^n \sum_{j=1}^n w_{ij}x_i(k) + \sum_{i=1}^n \theta_i x_i(k) \end{aligned} \quad (4)$$

since, $x_i \in \{-1, +1\}, \forall i$ so

$$L(X(k)) \geq -\frac{1}{2}\sum_{i=1}^n \sum_{j=1}^n |w_{ij}| - \sum_{i=1}^n |\theta_i| \quad (5)$$

Therefore, $L(X(k))$ is a lower Bounded function. The variation in the energy function $L(X(k))$ is then calculated

$$\begin{aligned} \Delta L(X(k+1)) &= L(X(k+1)) - L(X(k)) \\ &= -\frac{1}{2} X(k+1) W X^T(k+1) + \frac{1}{2} X(k) W X^T(k) + [X(k+1) - X(k)] \Theta^T \\ &= -\frac{1}{2} \sum_{i=1}^n \sum_{j=1}^n w_{ij} x_i(k+1) x_j(k+1) \\ &\quad + \frac{1}{2} \sum_{i=1}^n \sum_{j=1}^n w_{ij} x_i(k) x_j(k) + \sum_{i=1}^n \theta_i [x_i(k+1) - x_i(k)] \end{aligned} \quad (6)$$

Assume that the $k+1$ th iteration, only one neuron changes its state, namely, asynchronous updating is, then $x_j(k+1) = x_j(k)$, $\forall j \neq l$. Because $w_{ij} = w_{ji}$ and $w_{ii} = 0$, so

$$\begin{aligned} \Delta L(X(k+1)) &= -x_l(k+1) \sum_{j \neq l} w_{jl} x_j(k) + \sum_{j \neq l} w_{jl} x_j(k) + \theta_l [x_l(k+1) - x_l(k)] \\ &= -[x_l(k+1) - x_l(k)] (\sum_{j \neq l} w_{jl} x_j(k) - \theta_l) \\ &= -\Delta x_l(k+1) (u_l(k+1) - \theta_l) \end{aligned} \quad (7)$$

This paper defines the $\Delta x_l(k+1) = x_l(k+1) - x_l(k)$.

For the dual extreme values pattern $X(k+1)$, $\Delta x_l(k+1)$ are only three possible changes: $-2, 0$ and $+2$. Because the $\Delta L(X(k+1)) \leq 0, \forall k$. $L(X(k))$ is a lower Bounded function, so the states of all neurons within the limited number of iterations reach the energy function local minimum.

5.1. Storage phase

Assume that a set of N -dimensional vectors (binary word), denoted by $\{X_\mu | \mu=1, 2, \dots, n\}$ and is to be stored. These n vectors are called fundamental memories and represent the patterns to be memorized by the network. Let $X_{\mu i}$ denote the i th element of the fundamental memory, X_μ , where the class $\mu=1, 2, \dots, n$. From the outer product rule of storage, Hebb's hypothesis concerning the learning of the synaptic weight from neuron i to neuron j is generalized as

$$W_{ji} = \frac{1}{p} \sum_{\mu=1}^n X_{\mu j} X_{\mu i} \quad (8)$$

where $1/p$ is taken as a constant to simplify the mathematical description of information retrieval (Tappert et al., 1990). Notably, the learning rule in Eq. (8) is a "one shot" computation.

5.2. Retrieval phase

Given a recognizing pattern vector \underline{X} as an input, the initial output value is $X(0)$. Every neuron follow-up output is computed using Eq. (9):

$$\begin{aligned} X_j(n+1) &= \text{sgn} \left(\sum_{i=1}^p W_{ji} X_i(n) - \theta_j \right) \\ &= \text{sgn} (u_j(n) - \theta) = \begin{cases} 1 & \text{if } u_j(n) > \theta_j \\ x_j(n) & \text{if } u_j(n) = \theta_j \\ -1 & \text{if } u_j(n) < \theta_j \end{cases} \end{aligned} \quad (9)$$

Hopfield originally used 0 and 1 as the outputs (Graves et al., 2008). However, 1 and -1 are now commonly used to allow convenient use of the zero thresholds (Zixin and Shuxiang, 2011; Chai et al., 2008). The Hopfield network uses an asynchronous method to alter individual neuron output, with the complete associative memory process employed in Eq. (10) used to describe the chain-state relationship

$$\underline{X}(0) \rightarrow \underline{X}(1) \rightarrow \underline{X}(2) \rightarrow \dots \rightarrow \underline{X}(k) \rightarrow \underline{X}(k+1) \rightarrow \dots \quad (10)$$

Although \underline{X} converges on the stable state and sometimes also on the incorrect recall, our research uses the Hamming distance

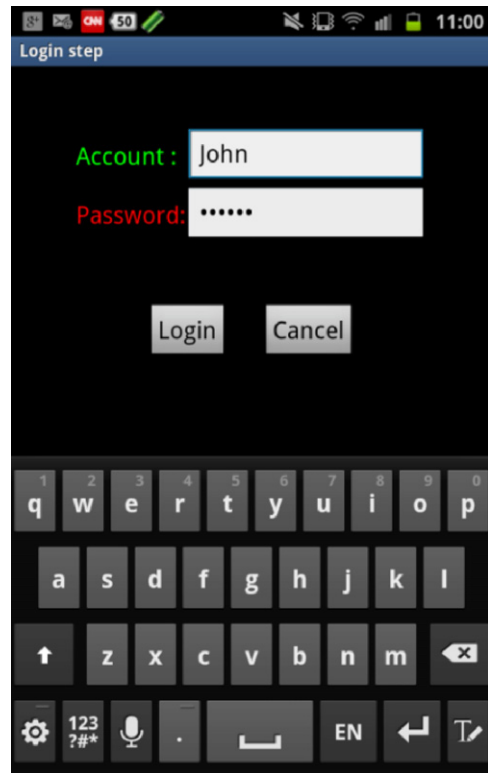

Fig. 15. Using a correct account and password to login to the home safety system.

Table 1 Assume that the family has four members.

Identity	Login Data	Handwriting Samples
Father	1. Account:John 2. Password:xxxxxx	John; John; John
Mather	1. Account:Mary 2. Password:xxxxxx	John; John Mary; Mary; Mary
Brother	1. Account:Tom 2. Password:xxxxxx	Mary; Mary Tom; Tom; Tom
Sister	1. Account:Lucy 2. Password:xxxxxx	Tom; Tom Lucy; Lucy; Lucy Lucy; Lucy

to effectively improve the local convergence spurious state (Sung-Jung et al., 2004).

6. Implementation

The user first logs-in to the HSHPR system and then goes to the identification mode. The correct account and password are input here. Please refer to the steps in Fig. 15 for details.

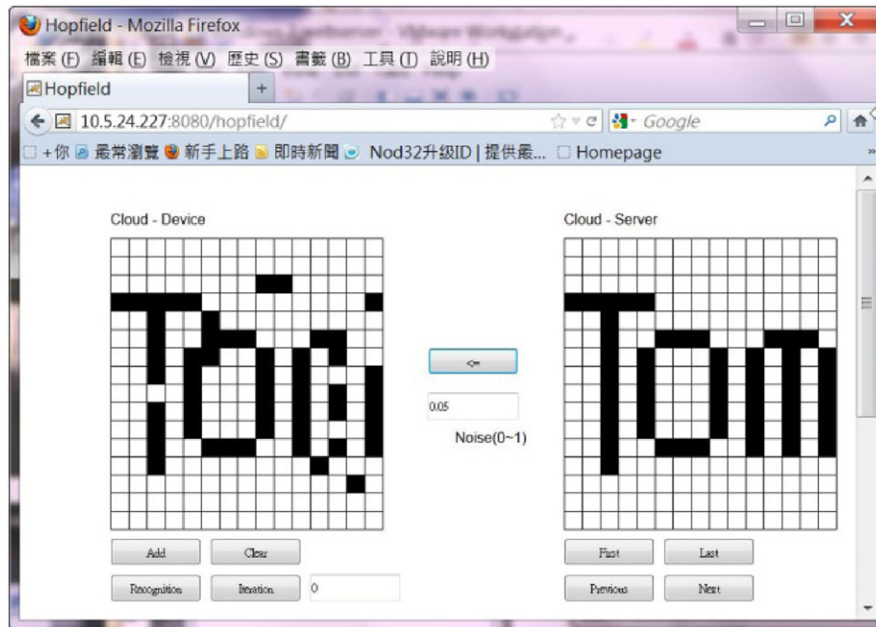

Fig. 16. Patterns are inputted at the cloud-device.

In the real implementation each account login requires five signature training patterns. When the five signature training patterns are established users are asked to write a handwriting sample. Our study considers the handwriting variations. For example, each account and the situation created by the hand-written template words are shown in Table 1.

The training pattern method is divided into many blocks. This research can effectively reduce the training time and improve the identification accuracy (Sung-Jung et al., 2004). The new learning pattern uses a dynamic method and can thus perform pattern recognition at any time. The measured pattern database and cloud-device operation results are recorded on a web page, as displayed in Fig. 16.

Fig. 16 shows the left side of the web page as the cloud-device and the right side of the web page is the cloud-server (Sung-Jung et al., 2002, 2004). If the user inputs a pattern at the cloud-device the result recognized as correct is displayed at the recognition result even when the source pattern of the cloud-device suffers from noise interference, as shown in Fig. 17.

Our paper uses a split training pattern database to solve the Hopfield network capacity problem (Sung-Jung et al., 2004). The proposed recognition system has already overcome many of the problems in previous systems (Zixin and Shuxiang, 2011; Chai et al., 2008). For example, the proposed system has substantially better capacity and accuracy than existing systems. The neural network with distributed computation is highly efficient. This investigation now analyzes the recognition system convergence with reference to Lippmann's experiment in which the inputs were assumed to take the value +1 for black points and -1 for white points. A selected pattern is distorted randomly and independently reversing each point of the pattern from +1 to -1 and vice versa, with a probability of 0.25, and then testing the network using the corrupted pattern. Fig. 18 illustrates the recognition results for a component pattern. The patterns produced by the network after 30, 100, 150 and 240 iterations reveal a steady increase in network output resemblance to the component pattern. After 238 iterations the network converges onto the correct component pattern form. Fig. 17 shows the correct stable convergence pattern after 240 iterations at the recognition result.

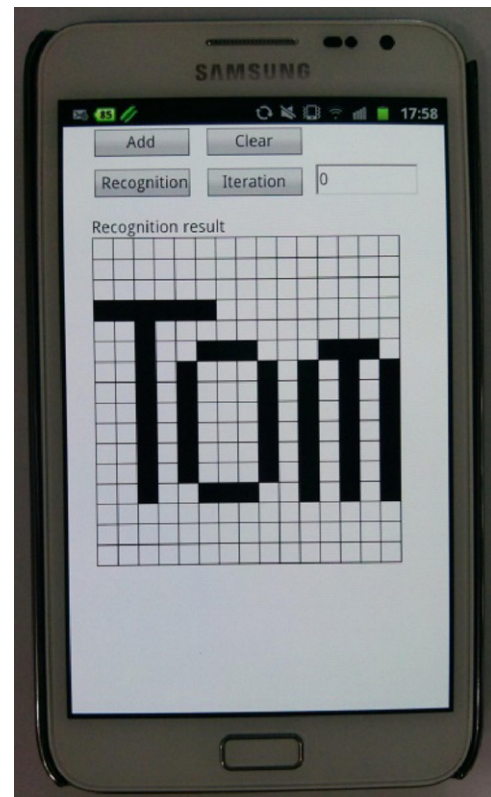

Fig. 17. Patterns of recognition finish are displayed at the result area.

Users perform the first and second stages of the recognition rate up to 100%. If the first stage is canceled, only the second phase of the recognition work is implemented and the recognition rate will vary due to system capacity. If users use distributed computing recognition the recognition rate can reach about 83%, please refer to Fig. 19.

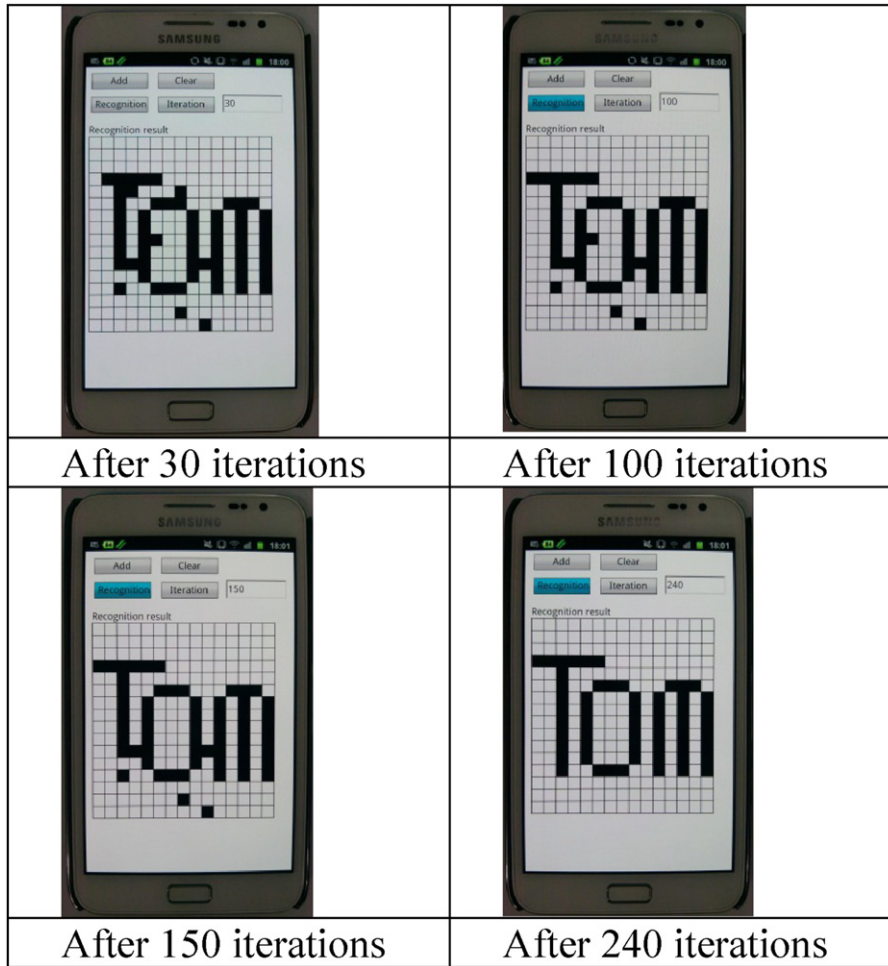

Fig. 18. Complete pattern recognition system in the convergent process.

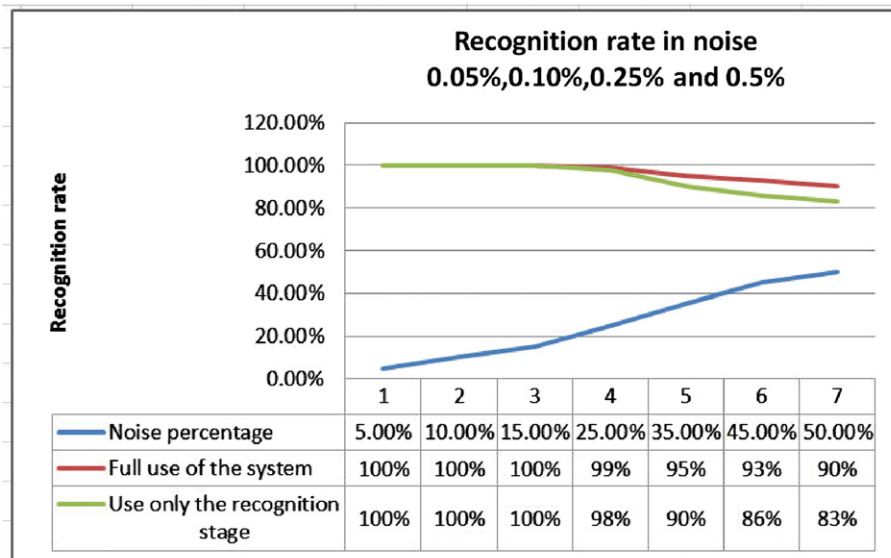

Fig. 19. Recognition rate in noise 5%, 10%, 0.15%, 0.25%, 0.35%, 0.45% and 50%.

Fig. 20 shows the ZigBee XBee Series 2 of wireless communication module. Fig. 21 shows the ZigBee coordinator setting, and Fig. 22 shows the ZigBee Router (or end device) configuration. Fig. 23 shows these Coordinators and Routers real-time messaging communications.

7. Conclusions and future work

In accordance with the relevant literature the ZigBee anti-noise network is the best wireless network technology. Our research

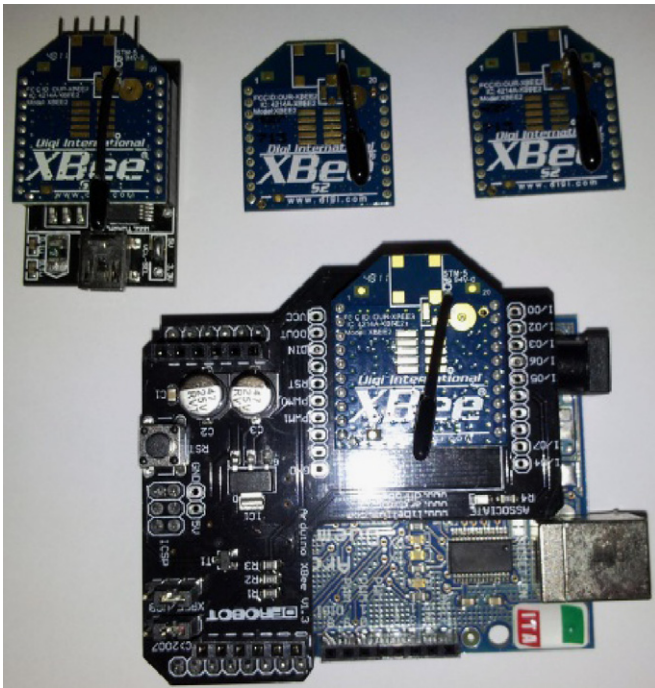

Fig. 20. ZigBee XBee Series 2 of wireless communication module.

integrated the advantages of ZigBee and Wi-Fi networks to compensate for standard network shortcomings.

This work obtained some new improved network solutions, as follows:

- Using the Arduino the Mega 2560 features to overcome the multiple serial ports simultaneously transmit the communication information.
- The Arduino controller integrate ZigBee and Wi-Fi module that will effectively enhance the intelligent control system.
- Using handwriting recognition technology to confirm identity will not infringe on personal bio-metric privacy.
- The computer no longer uses an external RS-232 hardware control circuit, but uses a highly efficient module control, which eliminate set-up difficulty.

With further development the proposed integrated system will be widely applied to intelligent control. Experimental control projects using the smart phone operating system is our next research effort. This research is still under development, some elements of a person's signature may have some difficulties in identification. When real signatures are neatly written words the identification process is perfect. However people's signatures are often scrawled producing incorrect recognition. Our handwriting area 15×16 grid modified to 30×32 or larger, handwriting recognition rate will be improved a lot, but also suitable for more

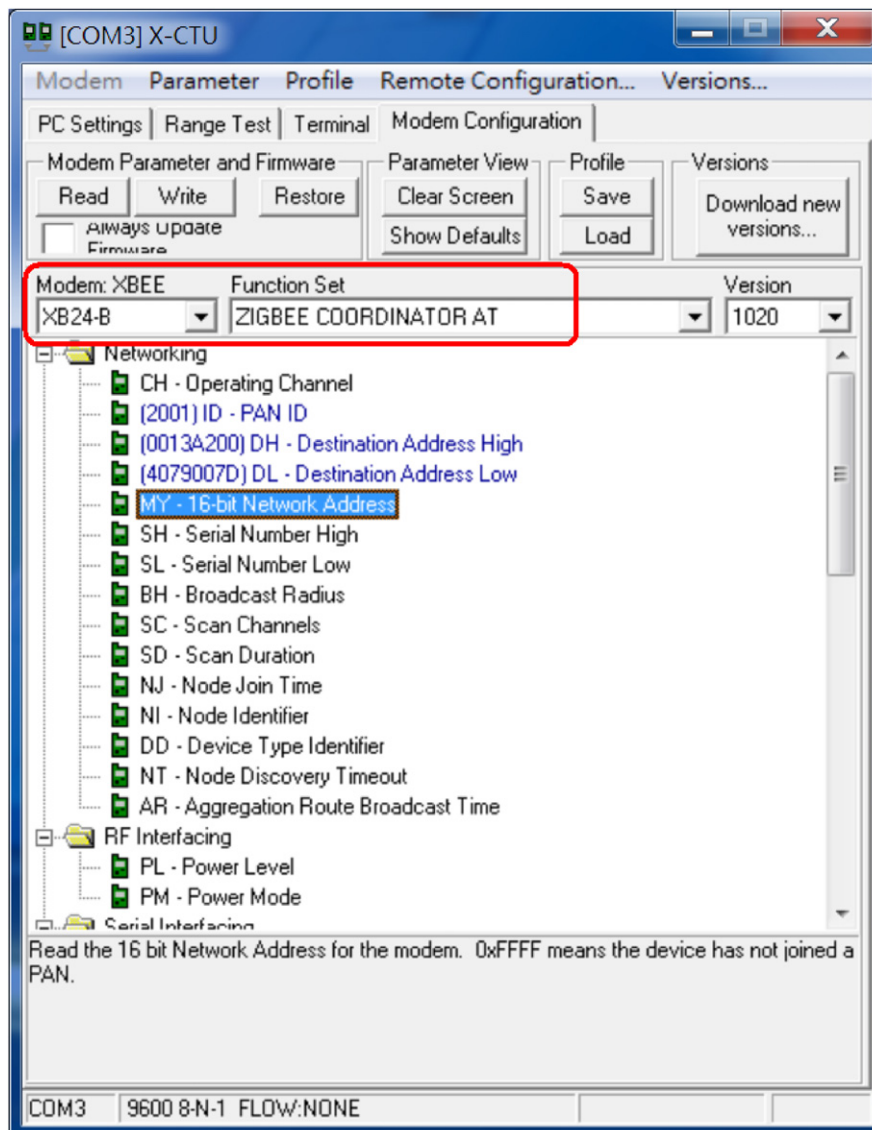

Fig. 21. ZigBee coordinator role setting.

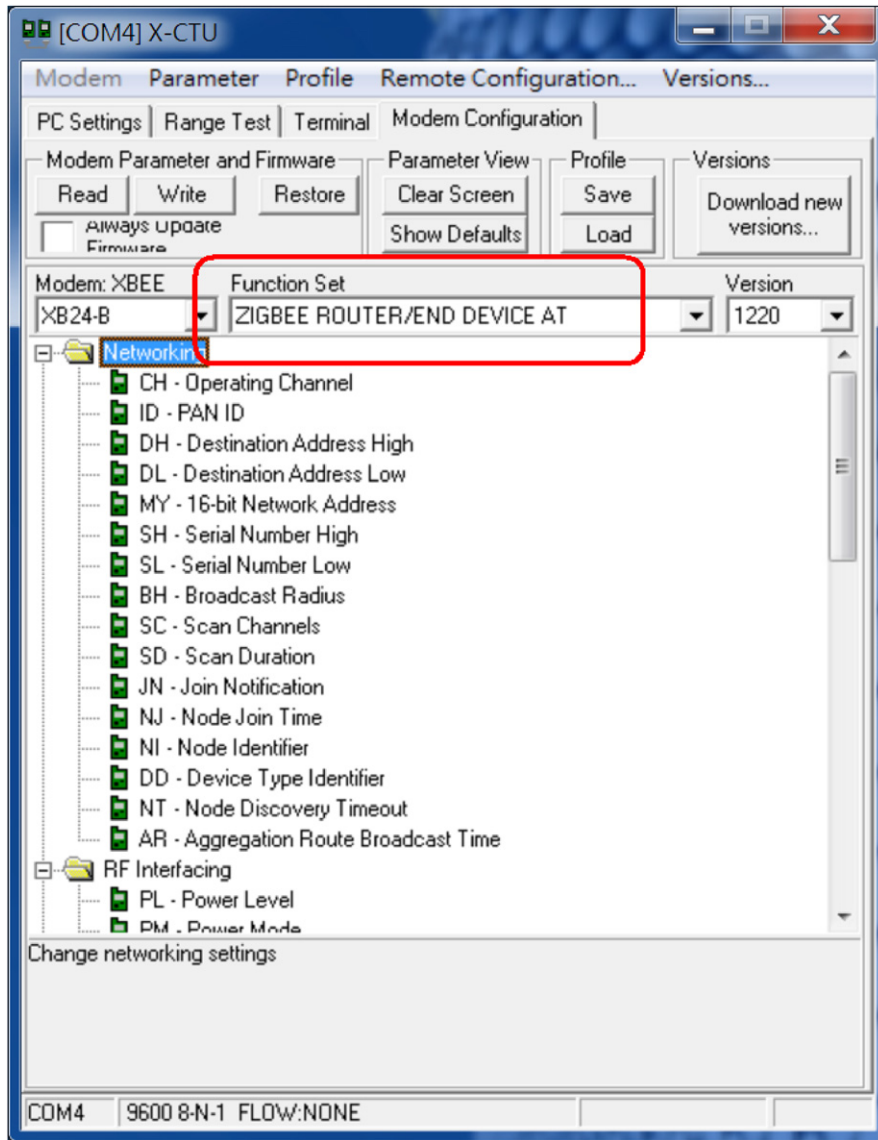

Fig. 22. ZigBee Router (or end device) configuration.

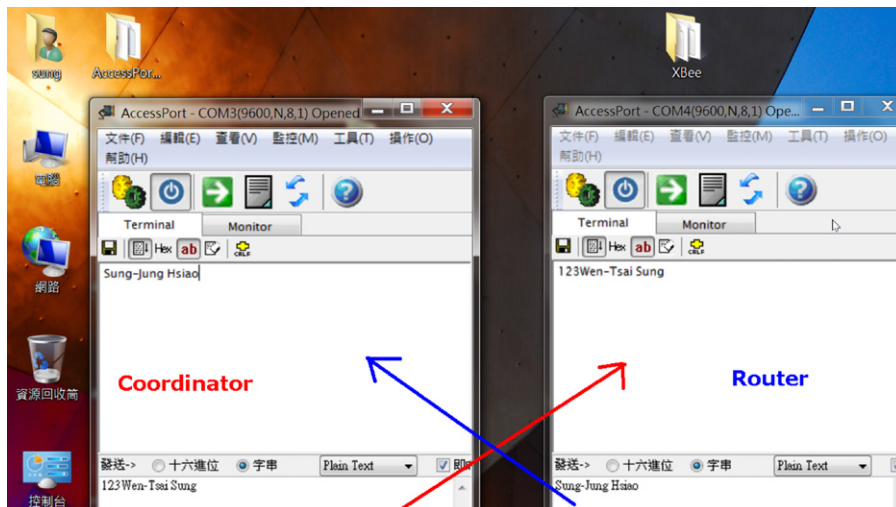

Fig. 23. These coordinators and Routers real-time messaging communications.

real handwriting. Future research will be to improve this disadvantage.

Acknowledgments

This research was supported by the National Science Council of Taiwan under grant NSC 100-2218-E-167-001-. The authors would like to thank the National Taipei University of Technology, Taiwan and National Chin-Yi University of Technology, Taiwan for financially supporting this research.

References

- Chai Yan-Jie, Sun Ji-Yin, Gao Jing, Tao Ling-Jiao, Ji Jing, Bao Fei-Hu. 2008 International Conference on improvement of I2C Bus and RS-232 Serial Port under complex electromagnetic environment. *Computer Science and Software Engineering*. Xian: Xian Research Institute of Hi-Tech; 2008. p. 178–81.
- Chen Thomas, Fu Zhi, He Liwen, Strayer Tim. Recent developments in network intrusion detection. *IEEE Network* 2009;23(1):4–5.
- Erdem Hamit, Üner Armagan. A multi-channel remote controller for home and office appliances. *IEEE Transactions on Consumer Electronics* 2009;55(4).
- Graves A, Fernandez S, Liwicki M, Bunke H, Schmidhuber J. Unconstrained online handwriting recognition with recurrent neural networks. *Advances in Neural Information Processing Systems* 2008(21):577–84.
- Graves Alex, Liwicki Marcus, Fernández Santiago, Bertolami Roman, Bunke Horst, Schmidhuber Jürgen. A novel connectionist system for unconstrained handwriting recognition. *IEEE Transactions on Pattern Analysis and Machine Intelligence* 2009;31(5).
- Hribernik KA, Ghrairi Z, Hans C, Thoben K-D. Co-creating the Internet of things—first experiences in the participatory design of intelligent products with arduino. In: *Proceedings of the 17th international conference on concurrent enterprising (ICE)*; 2011. p. 1–9.
- Hsiao Sung-Jung, Fan Kuo-Chin, Sung Wen-Tsai, Ou Shih-Ching. Web-based system of pattern recognition for component patterns database by innovative algorithms. *Malaysian Journal of Computer Science* 2002;15(2):78–93.
- Hsiao Sung-Jung, Sung Wen-Tsai, Ou Shih-Ching. Web-based search system of pattern recognition for the pattern of industrial component by an innovative technology 2004;53(2):179–92 Elsevier Company *Computers in Industry* 2004;53(2):179–92 Elsevier Company.
- Khmelevsky Youry, Voytenko Volodymyr. Cloud computing infrastructure prototype for university education and research. In: *Proceedings of the 15th Western Canadian conference on computing education*, ACM; 2010.
- Lien Chia-Hung, Bai Ying-Wen, Lin Ming-Bo. Remote-controllable power outlet system for home power management. *IEEE Transactions on Consumer Electronics* 2007;53(4).
- Lien Chia-Hung, Bai Ying-Wen, Lin Ming-Bo. Remote controllable power outlet system for home power management. *IEEE Transactions on Consumer Electronics* 2007;53:1634–41.
- Tappert C, Suen C, Wakahara T. The state of the art in online handwriting recognition. *IEEE Transactions on Pattern Analysis and Machine Intelligence* 1990;12(8):787–808.
- Teixeira Cláudio, Azevedo Ricardo, Sousa Pinto Joaquim, Batista Tiago. User provided cloud computing. In: *Proceedings of the 10th IEEE/ACM international conference on cluster, cloud and grid computing*. IEEE Computer Society; 2010.
- Teng J, Snoussi H, Richard C. Decentralized variational filtering for target tracking in binary sensor networks. *IEEE Transactions on Mobile Computing* 2010;9(10):1465–77.
- Vernon Scott, Joshi S. Senior member, IEEEbrain–muscle–computer interface: mobile-phone prototype development and testing. *IEEE Transactions on Information Technology in Biomedicine* 2011;15(4).
- Yang Yu-Chen, Wang Sheng-Tien, Tseng Yi-Jen, Koong Lin Hao-Chiang. Light up! Creating an interactive digital artwork based on Arduino and Max/MSP design. In: *2010 International computer symposium (ICS)*; 2010. p. 258–63.
- Yuksekkaya B, Kayalar AA, Tosun MB, Ozcan MK, Alkar AZ. A GSM, internet and speech controlled wireless interactive home automation system. *IEEE Transactions on Consumer Electronics* 2006;52(3):837–43.
- Zhao Zixin, Guo Shuxiang. A CDMA acoustic communication system for multiuser based on sound card. In: *2011 IEEE international conference on information and automation (ICIA)*. Takamatsu, Japan: Faculty of Engineering, Kagawa University; 2011. p. 69–74.